

Electric Conveyor Toaster

TT-WE1029A

TT-WE1029B

TT-WE1029C

User's Manual

TWOTHOUSAND.COM

Dear User & Client,

Firstly, thanks for purchasing and using our product. All the information and guidelines of this user's manual comply with certain applicable regulations, which come out from our long-term accumulated knowledge and experience as well as current project development situations.

Limited to some special structures, additional specified items or new technology changes, the actual usage situation might be some different from what stated in this user's manual. Should you have any question, please do not hesitate to contact the manufacturer via the method shown in back cover page of this manual.

For safety purpose and efficient operation, please make this document available to users for reference. Do have them to read this manual carefully before carry out any action on this device, especially when starting.

The manufacturer declines any responsibility in the event users do not follow the instructions or guidelines stated here.

The user's manual should be placed close to the device, in convenience of users' reading before operation. We have the full authority to reserve the further technical changes of the device, in the scope of further performance improvement characteristic development.



Warning

- ◆ Any self-modification, wrong installation, adjustment or maintenance can lead to property loss or casualty. Please contact the manufacturer for any adjustment or maintenance, and have the work done by a trained & qualified person.
- ◆ For your safety sake, please keep the machine away from any liquid, gas or other object, which is flammable or explosive.
- ◆ This appliance should not be operated by those who have physiological, perceptual or mental disabilities or those who have insufficient experience or knowledge (including children). Only in conditions of being given sufficient supervise & guarantee of personal safety, as well as proper instructions & guidance, those who were mentioned above can make some particular operation of this device.
- ◆ Keep children away from the device.
- ◆ Preserve this manual safely. When passing on/selling the device to a third party, the manuals must be handed over along with the device. All users must operate the device complying with the user's manual and related safety guidelines.
- ◆ Keep the mounting position away from flammable and explosive gas, liquid or object.
- ◆ If the appliance is placed near walls, partitions or kitchen furniture and the like, it is advisable to make these facilities with non-combustible material, otherwise cover them with non-combustible heat-resistant material, and pay attention to fire prevention regulations.

Contents

1. Functional Introduction.....	4
2. Structure Schematic Diagram & Working Principle.....	4
3. Basic Features & Parameters.....	5
4. Precautions & Recommendations.....	6
5. Working Instructions & Operation Flow.....	9
6. Routine Inspection.....	11
7. Cleaning & Maintenance.....	11
8. Failure Analysis & Trouble Shooting.....	12

TWOTHOUSAND.COM

1. Functional Introduction

This product is manufactured by our company, which is combined with advantages from home and abroad. It is novel in design, reasonable in structure, easy in operation, stainless steel in making, durable in using and convenient in maintenance. The thermostatic control makes the temperature adjustable freely according to food requirement within a certain range. Therefore, it is the ideal equipment for hotel, supermarket, western restaurant, fast-food restaurant and food industry.

2. Structure Schematic Diagram & Working Principle

2.1 Structure Schematic Diagram:

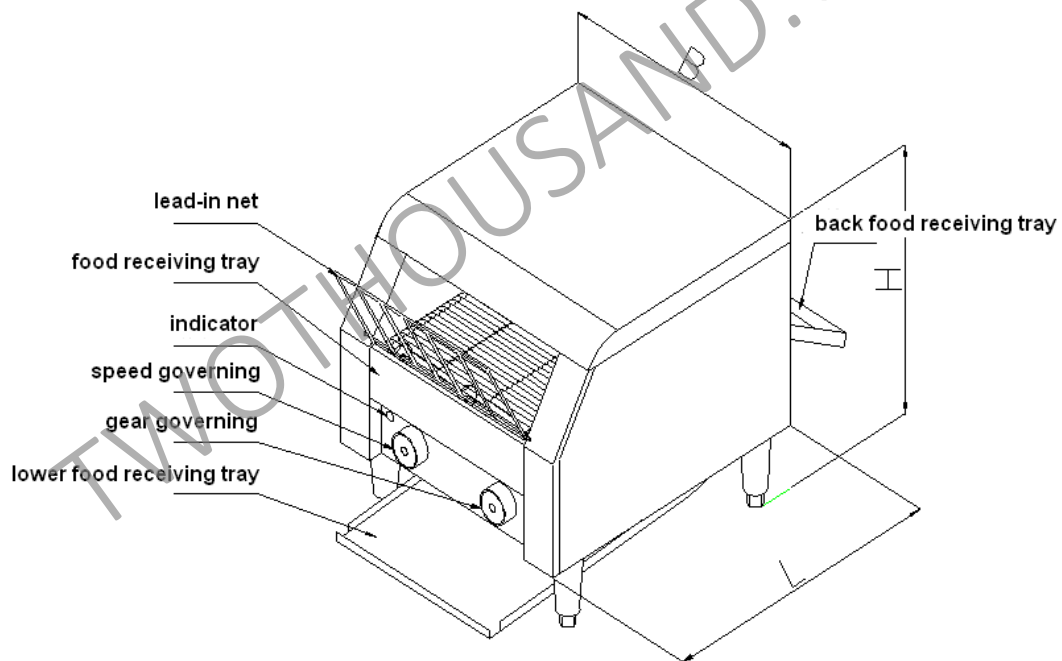

2.2 Structural & Functional Features

1. The color of bread is controlled through regulating the speed of the conveyor chain.
2. Lead-in net rack is equipped to ensure the smooth loading of the bread.
3. Food receiving tray is equipped to collect the scrap.
4. With both front bread lead-out and back bread lead-out styles to meet the different needs of the users, very easy to operate.

2.3 Electrical Diagram:

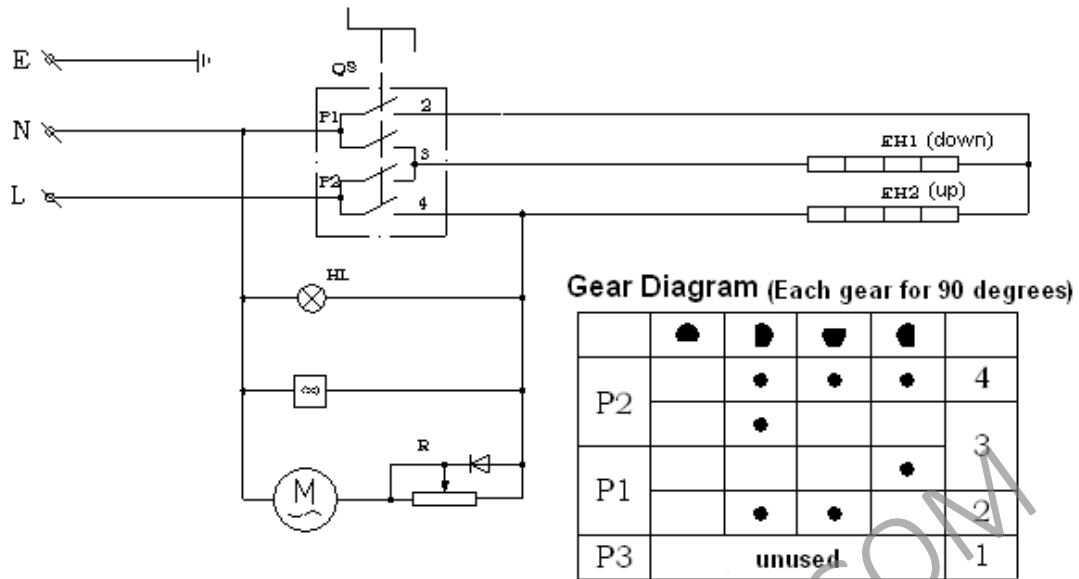

HL1-----power indicator ∞-----electric fan EH1, EH2-----heating element
 R-----speed governing M-----motor QS-----gear switch

3. Basic Features & Parameters

Model	TT-WE1029A	TT-WE1029B	TT-WE1029C
Dimension (MM)	288×418×387	368×418×387	468×418×387
Capacity (Pieces/Hour)	150-180	300-350	450-500
Power (KW)	1.34	2.24	2.64
Voltage (V)	220-240	220-240	220-240
N/W (KG)	14	16	20.5

4. Precautions & Recommendations

4.1 Transportation and Storage

During transportation, the machine should be carefully handled and do not put it upside down to prevent from damaging to the shell and inside. The packaged machine should be stored in a ventilated warehouse without corrosive gas. If it needs to be stored in open air temporarily, measurement against raining is needed.

4.2 Notice for Installment

Accessories installation:

1. Have the appliance unpacked and take out the following accessories: a food receiving tray, a back food receiving tray, a lead-in net and four adjustable feet.
2. First, screw the four adjustable feet into the screw holes at bottom in right rotation. Then, put them onto the operating platform with proper height. For safe operation sake, please level the machine by adjusting the adjustable feet.
3. Insert the hooks on both sides of lead-in net into mounting hole of the net as indicated in Picture 1.
4. Installation of lower food receiving tray: hang the lower food receiving tray on nail ① in the arrow direction as indicated in Picture 2.
5. Installation of back food receiving tray: hang the lower food receiving tray on nail ② in the arrow direction as indicated in Picture 3.

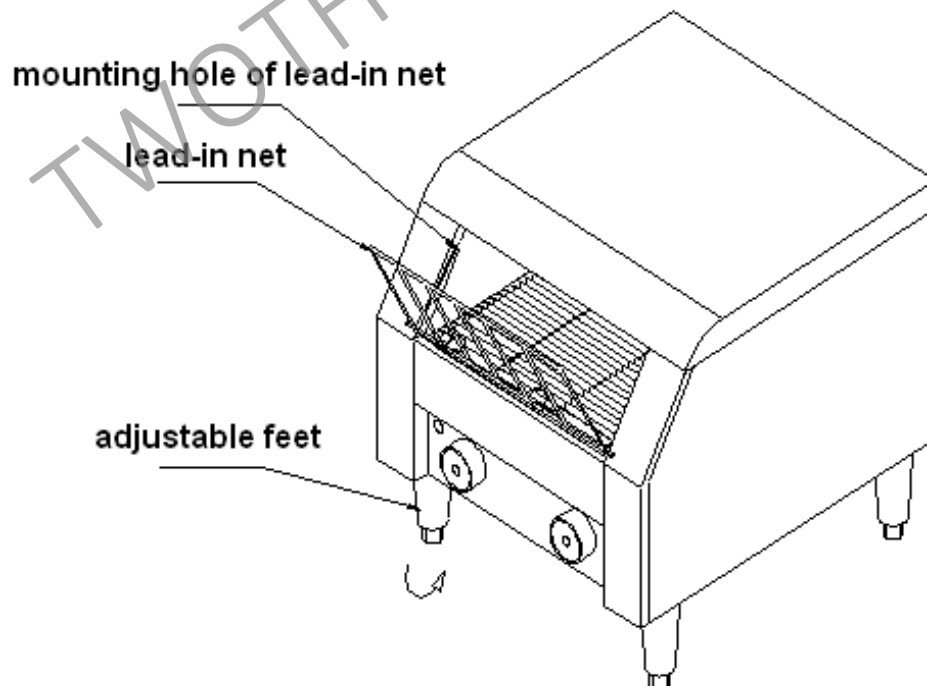

Picture 1

Picture 2

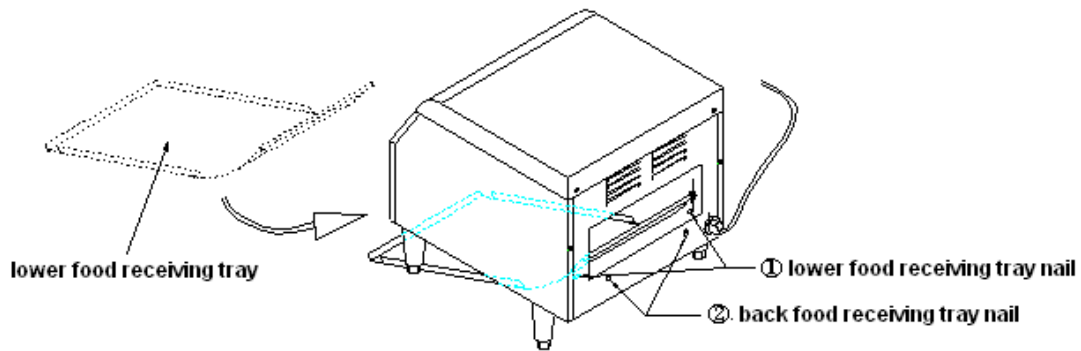

Lower Food Receiving Tray Mounting Diagram

Picture 3

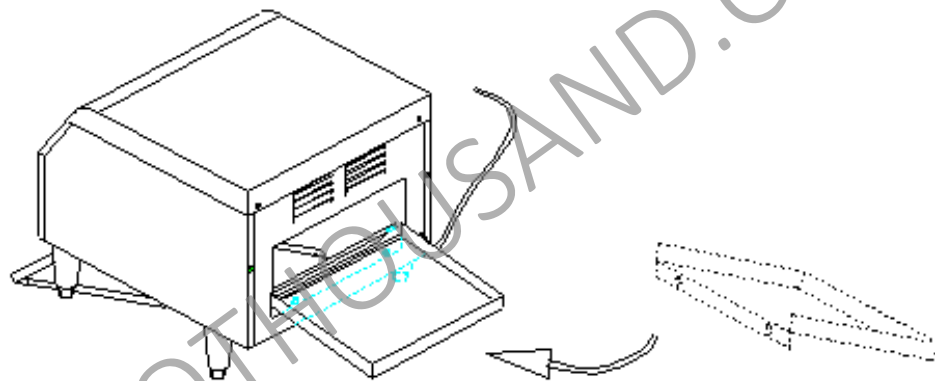

Back Food Receiving Tray Mounting Diagram

Electric installation:

1. The supply voltage should correspond with the working voltage of the appliance.
2. The fixed arrangement of wire should be equipped with a all-poles disconnecting switch whose poles have a contact separation at a minimum clearance of 3mm. Grounding leakage protection switch is recommended. Do not put any sundries in front of the switch for convenient operation sake.
3. There is an earth stud at rear of the furnace body, which should be connected with a copper wire that no less than 1.5mm² and ground wire that complying with safety regulations reliably.

Notice:

1. Check the connection, voltage and safety grounding after installation.
2. The appliance should be placed in a smooth area and kept a minimum clearance of 10cm away from the incombustible object on both sides and 20cm at the back (e.g. walls, windows etc.).
3. The mounting position should keep away from the flammable and explosive objects. The ambient temperature should below 45°C and the relative humidity should below 85%.
4. Installation should be operated by professional technician.

4.3 Special Notice

1. This appliance is not applicable for home use.
2. This product is a commercial machine that needs to be operated by trained cook.
3. Do not sway or tilt the machine during operation.
4. Do not dismantle or self-modify the machine.
5. Dismantlement and self-modification may cause casualty.
6. Do not open the casing of the machine.
7. This product contains high-voltage circuit. Casing dismantlement may cause electric shock.
8. Unplug and cut the power supply off before cleaning.
9. Do not spray water directly onto the product during cleaning.
10. Water may conduct electricity, which may cause electric shock.
11. Do not pat the product or put any heavy objects onto it.
12. Abnormal operation may cause damage and danger.
13. High temperature may cause scald.
14. Do not touch the appliance with hands directly due to high temperature during or after operation.
15. To prevent from damages, turn the electric switch off as soon as possible when near the thunder zone.
16. Do not destroy the control panel with hard or sharp objects.
17. Turn the electric switch off when finish working.
18. Maintenance should be done by qualified technicians. It is risky to be operated by other people.

5. Working Instructions & Operation Flow

1. Before using, check that whether the power supply installation is normal and make sure the power supply voltage corresponds to the working voltage of the appliance.
2. After connecting the machine to the power supply, the indicator is on. Rotate the left speed governing knob (COLOUR CONTROL) to “3” position. (Notice: The lighter the color is, the faster the speed of chain movement is.) Rotate the right gear switch knob to “BREAD” position; meanwhile, heating elements of upper and lower layer start heating simultaneously, the chamber temperature rises gradually. If no bread in the chamber, the max temperature of midpoint in the chamber can reach 284°C in 12min. Then, it keeps constant in 284°C generally.
3. Before baking, please energize the appliance and preheat for about 10-12min. Then, try baking with two pieces of bread to see the color degree so as to adjust the chain speed. To bake bread with deeper color, please turn the knob clockwise from the color circle with deeper color to position whose scale is larger than “3”. (Notice: The deeper the color of color circle and the larger the scale value is, the slower the chain moving speed and the deeper the bread color is, and vice versa.) After chain speed adjustment, put the bread on the chain via lead-in net rack, the bread will be passed into the toaster to bake with the movement of chain.
4. The baked bread will be turned to the lower food receiving tray and slide from the lower food receiving tray to the front through the chamber bottom as indicated in Picture 4.
5. A back food receiving tray is equipped at the back. If you want to take out the bread from back side, press down the back slide board with handle at rear of furnace body to make the front of slide board have contact with the pin near chain wheel. The baked bread will slide from the back slide board to back food receiving tray as indicated in Picture 5. After the operation, hold the handle to pull up the back slide board to reset.
6. If baking steamed buns, rotate the right gear governing knob to “BUNS” position. The upper heating element works only. If warming is required, rotate the knob to “STBY” position.
7. When finish working, rotate the gear governing knob to “OFF” position and unplug.
8. To prevent pollution and performance damage of the appliance, do not use this toaster to bake food whose surface has too much sugar or sticky food that will flow out after heating.
9. If the power cord is damaged, please replace it with specialized cord or specialized component bought from the manufacturer or maintenance department. Replacement should be operated by professional personnel.

Picture 4

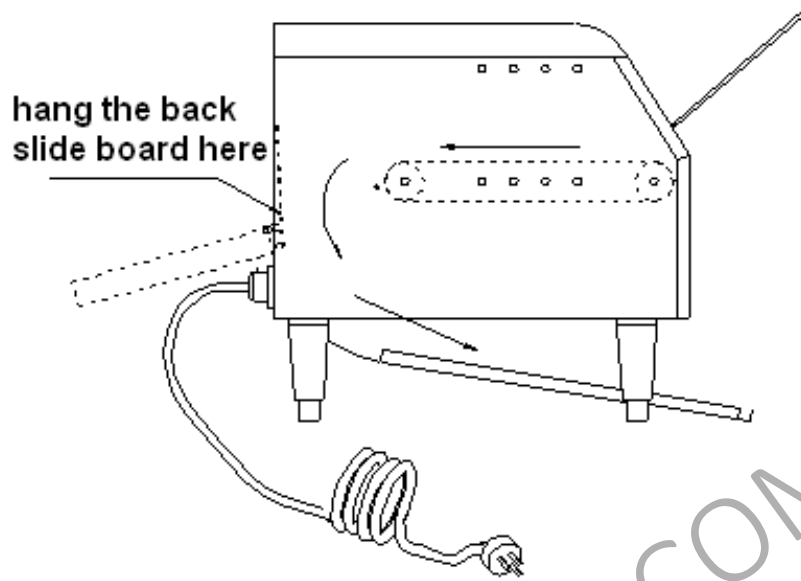

Picture 5

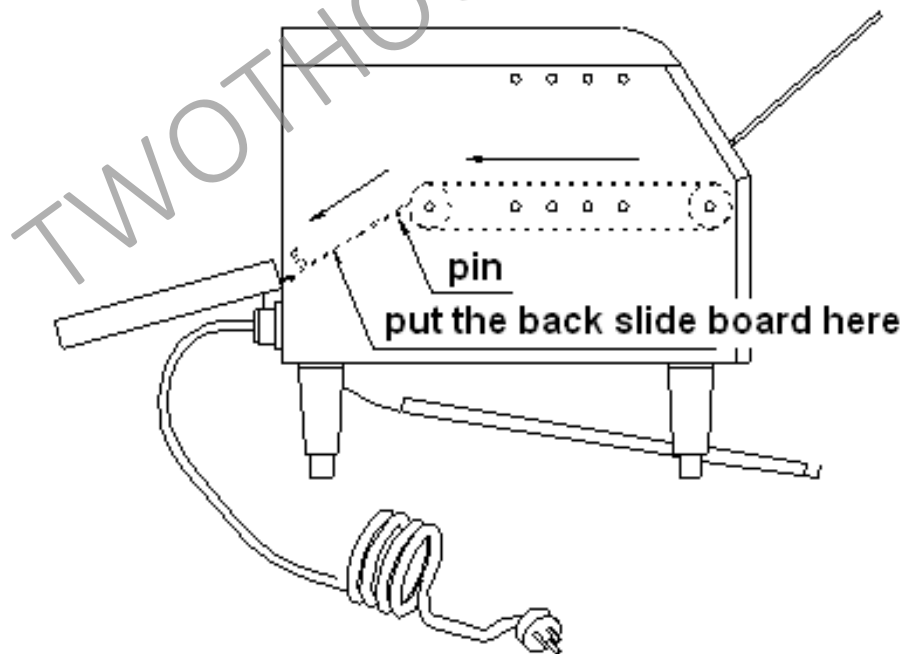

6. Routine Inspection

It is necessary to check the machine daily.

Check the machine regularly can avoid serious accident happens.

Stop using if user feels that there are some problems in the circuit or machine.

Check the situation of the machine before or after using every day.

Before using: Whether the machine is tilted?

Whether the control panel is damaged?

Whether the power line is aging, cracking or damaged?

During using: Whether there is strange smell or vibration noise?

Whether the temperature is out of control or any electric leakage?

7. Cleaning & Maintenance

1. In case of accident, please turn the power supply off before cleaning.
2. When finish working every day, pull out the food receiving tray to clean and scrub the furnace surface and power line with soft cloth containing non-corrosive detergent. Do not spray the appliance directly with water jet. Water infiltration may damage electric property and cause electricity safety accident.
3. If not going to use the appliance, please turn the thermostat and power switch off.
4. If not going to use the appliance for a long time, please clean it completely and store it in a well-ventilated warehouse without corrosive gas.

8. Failure Analysis & Trouble Shooting

Symptoms	Causes	Solutions
The power supply is connected and the heating indicator is on, but it does not heat up.	<ol style="list-style-type: none"> 1. The thermostat is damaged. 2. At least one of the heating wires burns out. 	<ol style="list-style-type: none"> 1. Replace the thermostat. 2. Replace the burnt-out heating wire.
Connect the power supply and rotate the thermostat, the heating indicator is on, but the temperature keeps rising and out of control.	<ol style="list-style-type: none"> 1. The thermostat does not work. 	<ol style="list-style-type: none"> 1. Replace the thermostat.
The power supply is connected and heating is normal, but the indicator is off.	<ol style="list-style-type: none"> 1. The indicator is damaged. 	<ol style="list-style-type: none"> 1. Replace the indicator.
It does not heat up and the indicator is off.	<ol style="list-style-type: none"> 1. The power supply is abnormal and disconnected. 2. The fuse is fused. 	<ol style="list-style-type: none"> 1. Check the power supply and connection to make it supply normally. 2. Replace the fuse.

Aforementioned troubles are just for reference. If any failure occurs, please stop using and inform professional technicians to check and repair.