

B10K MIXER

Circuit diagram

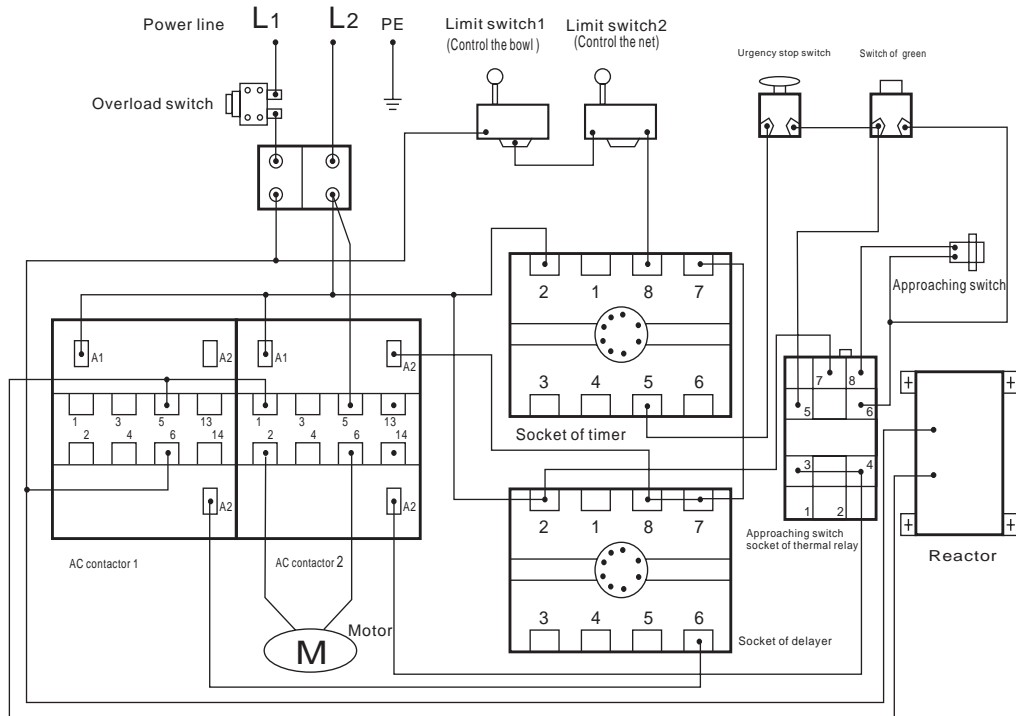

B10K

Mixer of multi-function high-speed



Technical parameters

INDEX

Mixer's dimensions 1

Figure1 Mixer's configuration 2

Figure2 Centre axle 3

Figure3 Gear axle 4

Figure4 Driving axle 5

Figure5 Complete of motor 6

Figure6 Fork and speed axle 7

Figure7 Complete of rise and drop 8

Figure8 Turning plate and mixing axle 9



Figure9 Standard accessories 10

Operation information and
 breakdown and settlement 11

Warning and special attention 12

Technical parameters 13

Circuit diagram 14

Type	B10K	
Safety Guard	Yes	
Mixer (L)	10	
Power supply (V)	230	
Input power (Hz)	50	
Rated power of input (W)	600	
Mixing speed (r/min)		460
		234
		118
Greatest capacity of flour(kg)	3.75~4.0	

B 10 K MIXER

WARNING AND SPECIAL ATTENTION

WARNING



- Don't rinsing with water pipes .
- Please pull the plug out before maintain the mixer and get maintenance to see to it.
- Is't dangerous of touching the electrical switch and power source by wet hand.
- When there are some damages in the mixer, please stop using it.
- There is a ground screw (Signed"⊥") , when the mixer needs to be repairing and be smooth to repair , finally you can not take off the ground wire.
- When the working , don't put your hands into the barrel and don't touching the mixing devices .
- Minors are not allow to close the mixer.
- Mixer must fix on the dry wooden and put the mixer in safety-working zone .
- If the electrical line was broken ,please get the profession maintenance to change it.

SPECIAL ATTENTION

- 1、 Before the using, you should clear the dirt away of the barrel and mixing , when you clear the mixing please carefully. And correct installation of barrel on the fork. Don't make it tilt.
- 2、 When you choosing the mixing devices , please in according to the nameplate's marked to choosing the correspond speed of, if you choosing wrong, it make the accessory was broken or reduce the mixer's service life.
- 3、 After using, please clear barrel and the mixing , then put they are in place of safety and clean-zone. Don't forget to cut off the power source .
- 4、 Please keep the dry, public health and safety environment surround the mixer .

B 10 K MIXER

Mixer' S dimensions

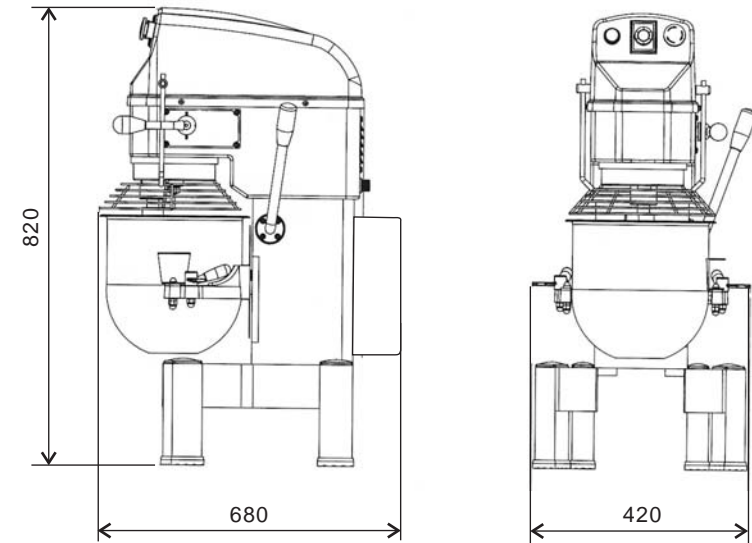

Attention :

- Don't rinsing with water pipes.
- Don't touching the electrical switch and power source by wet hand
- Please pull the plug out before maintain the mixer and get profession maintenance to see to

B10K MIXER

FIGURE 1 Mixer configuration

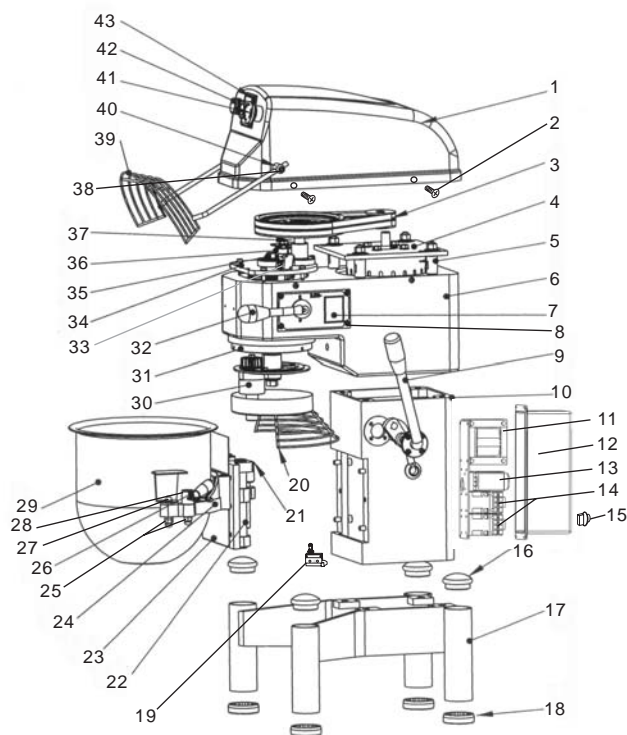

Accessory's name	Qty
1 Top cover	1
2 Screw M5*12	4
3 Belt of motor SPZ687	2
4 Motor	1
5 Axle of motor	4
6 Gear box	1
7 Name plate	1
8 Screw M4*6	1
9 Handle	1
10 Column	1
11 Reactor	1
12 Box	1
13 Switch of delayer	1
14 Alternating current contactor	2
15 Overload switch	1
16 Ruber	4
17 Substructure	2
18 Ruber 2	4
19 Switch of rise and drop	1
20 Axle of handle	1
21 Safety net 1	1
22 Guides	2
23 Holding-plate	1
24 Guides	1
25 Nut M8	4
26 Lock of bowl	2
27 Screw	2
28 Screw M8*50	2
29 Bowl	1
30 Turing plate	1
31 Inner gear ring	1
32 Ruber	1
33 Switch control safety net	1
34 Bearing cover	1
35 Centre axle	1
36 Gear axle	1
37 Initiative axle	1
38 Screw M8*16	2
39 Safety net 2	1
40 Axle of net	2
41 Urgency switch	1
42 Start-up switch	1
43 Timer	1

Attention :

- ▶ We are already imitted enough much lubricated grease, so it can be used for 3 year at normally , but you must change new grease after repairing .
- ▶ please tighten up a cover of avoiding grease after change the new grease .

B10K MIXER

Operation information

	▶ Before using, please check power voltage is suitable for voltage of this mixer or not and the ground wire is firm whether or not
	▶ Don't install any mixing tool before testing.
	▶ In according different mixing-material to choose different mixing devices and speed.
	▶ When the mixer has worked for a long time ,you must cool it down and restart the mixer.
Mixing III	▶ It is applied to mix liquid, such as cream, eggs, the working time don't more than 15 minuets.
Mixing I	▶ It is applied to mix mush, powder and smash objects. The working time don't more than 20 minutes.
Mixing II	▶ It is applied to mix dough and glutinous socover 5-7 kg. The working time don't more than 30 minutes and the dough moisture content at between the 40% to 50%.

Breakdown and settlement

Trouble	Probable cause	Remedy
Mixer can't run after switch on.	It is not good to touch electric.	Check the electric circuit.
Motor is to hot and speed decreases.	Not enough voltage or not suitable for choosing agitator.	Check the voltage or choose suitable position and agitator.
Oil leakage.	The oil seal broken.	Change the new one.
It's hard to raising handle.	Orbit is erosion or the handle's axle and cone gear are dry.	Clean the damaged one and put the lubricate grease.
The mixer's head noise and too hot.	The lubricated grease is not good.	Put in or change grease.
The mixing touches the barrel.	Mixing or barrel change the shape.	Repairing or change the mixing or barrel.
Without high, middle and low-speed output.	The flat key of 7# and figure 4 fret.	Change the flat key of 7# and figure 4.
There're high and middle-speed output without low-speed output.	The spring reed of clutch rupture or the gear ring broken.	Change the accessories.

B10K MIXER

FIGURE 9 Standard accessories

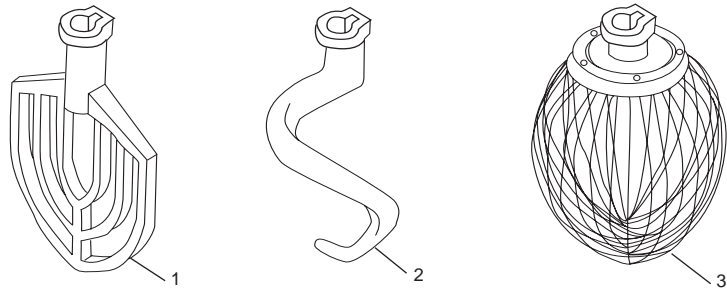

	Accessory' s name	Qty
1	Mixing 1	1
2	Mixing 2	1
3	Mixing 3	1
4	Barrel	1

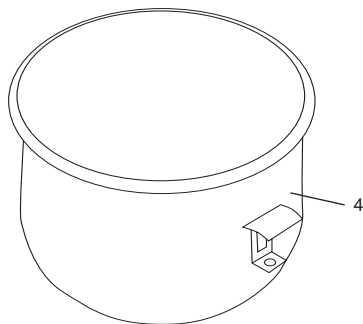

Attention :
 ➤ Any mixing easy to install and rotates the mixing clockwise to locked, push the mixing up and rotates counter-clockwise then remove the mixing.

B10K MIXER

FIGURE 2 Centre axle

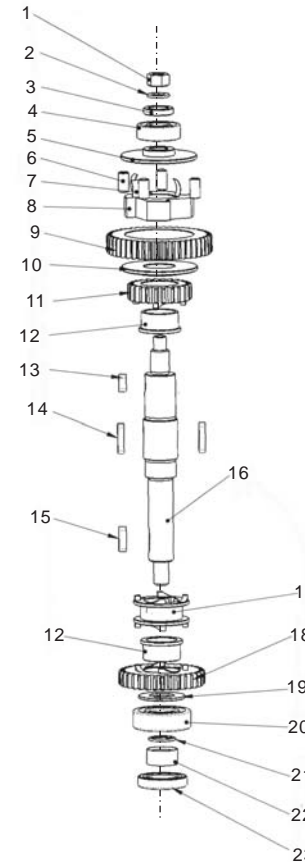

	Accessory' s name	Qty
1	Nut M10	1
2	Spring washer 10	1
3	Washer 10	1
4	Bearing 6202	1
5	Avoiding cover	1
6	Roller 8X16	4
7	Spring	8
8	Clutch	1
9	Gear ring	1
10	Dividing ring	1
11	Small joint gear	1
12	Bearing sleeve	2
13	Key 6X14	1
14	Key 5X24	2
15	Key 6X20	1
16	Centre axle	1
17	Joint gear	1
18	Big joint gear	1
19	Washer of centre axle	1
20	Bearing 6204	1
21	O ring 22.5X1.5	1
22	Sleeve of centre axle	1
23	Oil seel 25X40X8	1

Attention:

- After repairing. To ensure installed that the clutch and joint in accordance with the correct diagram.
- If the grease drop from bottom of centre axle ,please check the oil seal whether broken.
- In the demolition or install, due to avoiding the bearing to be broken, you should tap bearing out gently.

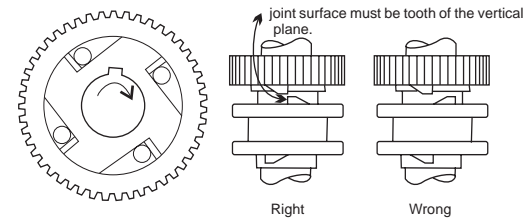
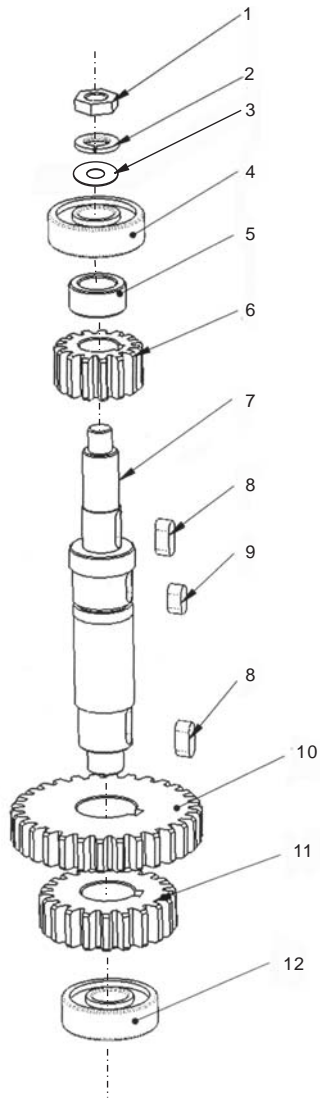

FIGURE 2-1

FIGURE 2-2

B10K MIXER

FIGURE 3 Gear axle



	Accessory' s name	Qty
1	Nut M8	1
2	Spring washer 8	1
3	Washer 8	1
4	Bearing 6201	1
5	Sleeve of gear axle	1
6	Gear wheel	1
7	Gear axle	1
8	Key 5X12	2
9	Key 5X10	1
10	High-speed gear	1
11	Low-speed gear	1
12	Bearing 6201	1

B10K MIXER

FIGURE 8 Turning plate and mixing axle

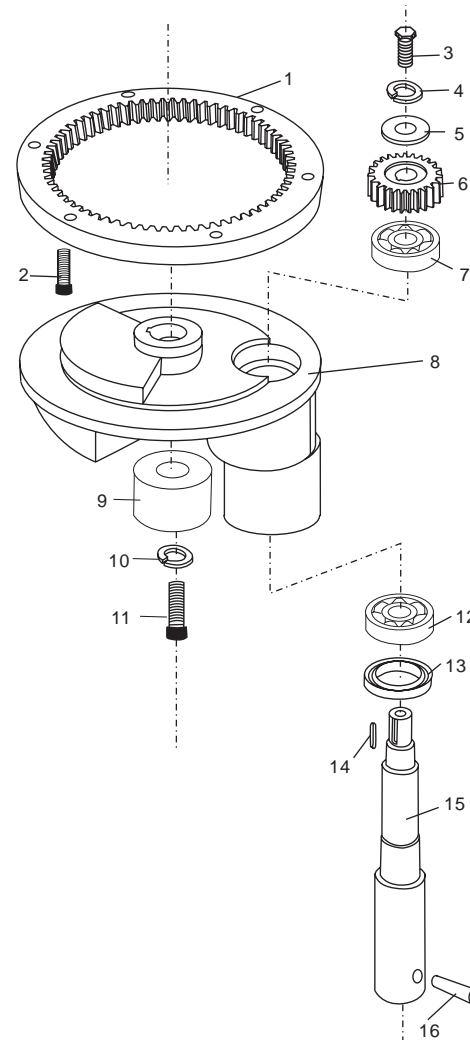

	Accessory' s name	Qty
1	Inner gear ring	1
2	Screw M6*16	6
3	Screw M6*16	1
4	Spring washer 6	1
5	Gasket	1
6	Planetary gear	1
7	Bearing 6203	1
8	Turning plate	1
9	压盖	1
10	Spring washer 8	1
11	Screw M8*20	1
12	Bearing 6003	1
13	Oil seal 20*40*10	1
14	Key 5*14	1
15	Mixing axle	1
16	Pin 6*25	1

Attention :

- ▶ When the mixer working ,there is noise with turning plate(8), it's the inner gear(1) was loose. Please pull the turning plate out, then tap at the inner gear and tightening the screw (2).

B10K MIXER

FIGURE 7 Rise and drop of barrel

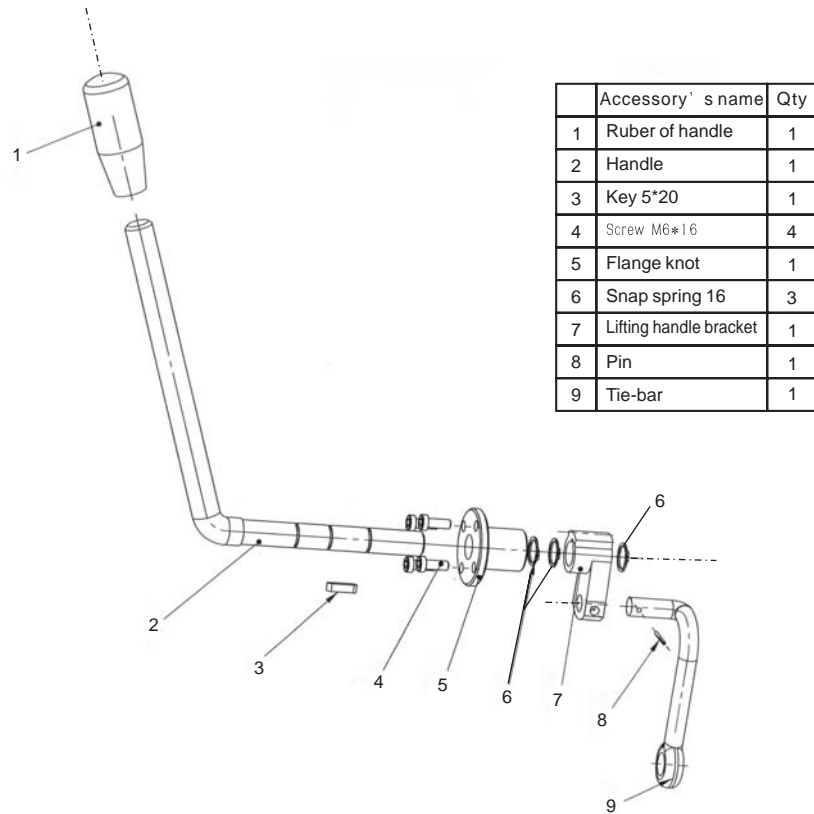

Attention :

- First drop the barrel to bottom, then pull the mixing out, at last take out barrel.
- Put the lubricated grease on the handle axle, the rise and drop pole and cone gear every month

B10K MIXER

FIGURE 4 Initiative axle

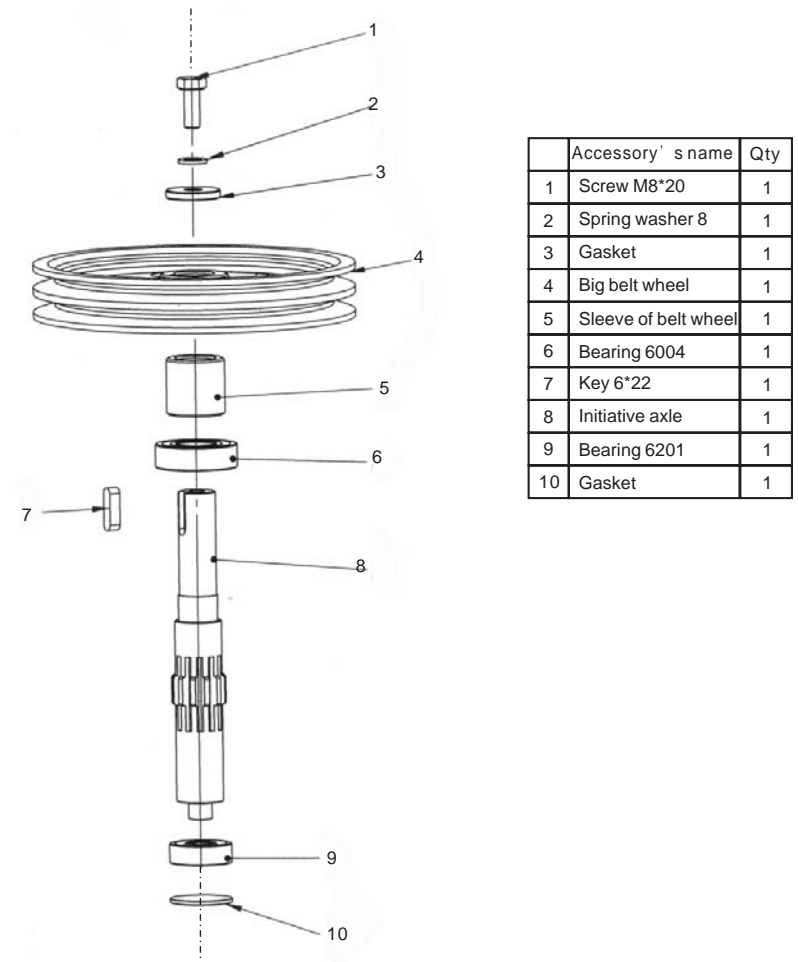

B 10 K MIXER

FIGURE 5 Motor

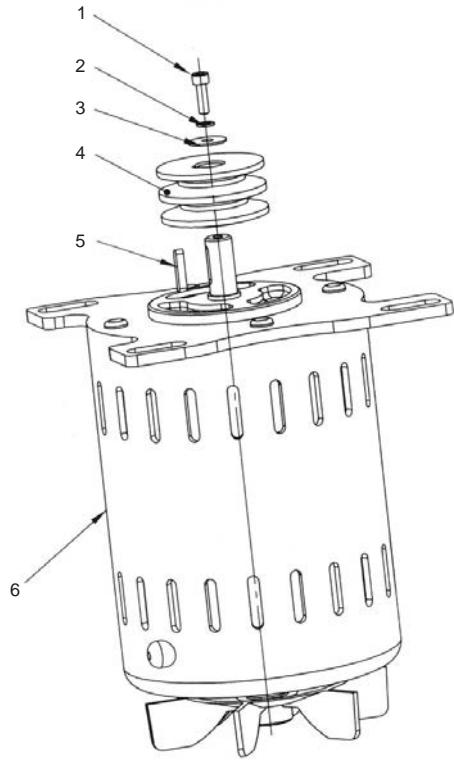

	Accessory' s name	Qty
1	Screw 5*16	1
2	Spring washer 5	1
3	Gasket	1
4	Belt wheel of motor	1
5	Key 4*20	1
6	Motor	1

B 10 K MIXER

FIGURE 6 Fork and change speed axle

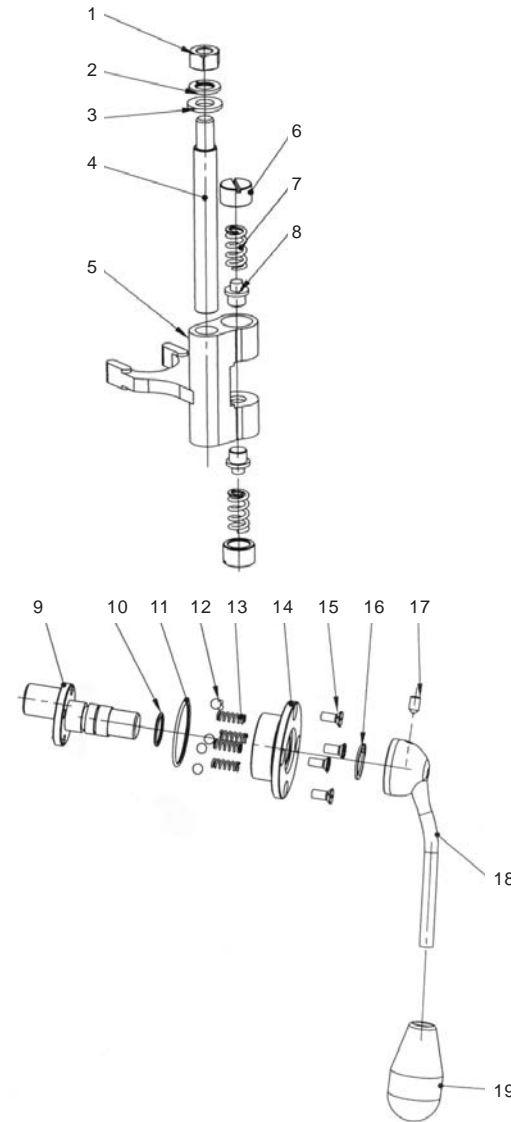

	Accessory' s name	Qty
1	Nut M10	1
2	Spring washer 10	1
3	Washer 10	1
4	Axle of fork	1
5	Fork	1
6	Nut	2
7	Spring	2
8	Shaft of fork	2
9	Axle of change speed	1
10	O ring 12*2.4	1
11	O ring 37,5*2	1
12	Steel bar $\phi 6$	4
13	Spring	4
14	Speed block	1
15	Screw M5*12	1
16	Snap spring 18	1
17	Screw M6*16	1
18	Handle	1
19	Ruber	1