

B40K MIXER

Circuit diagram (2) (380V)

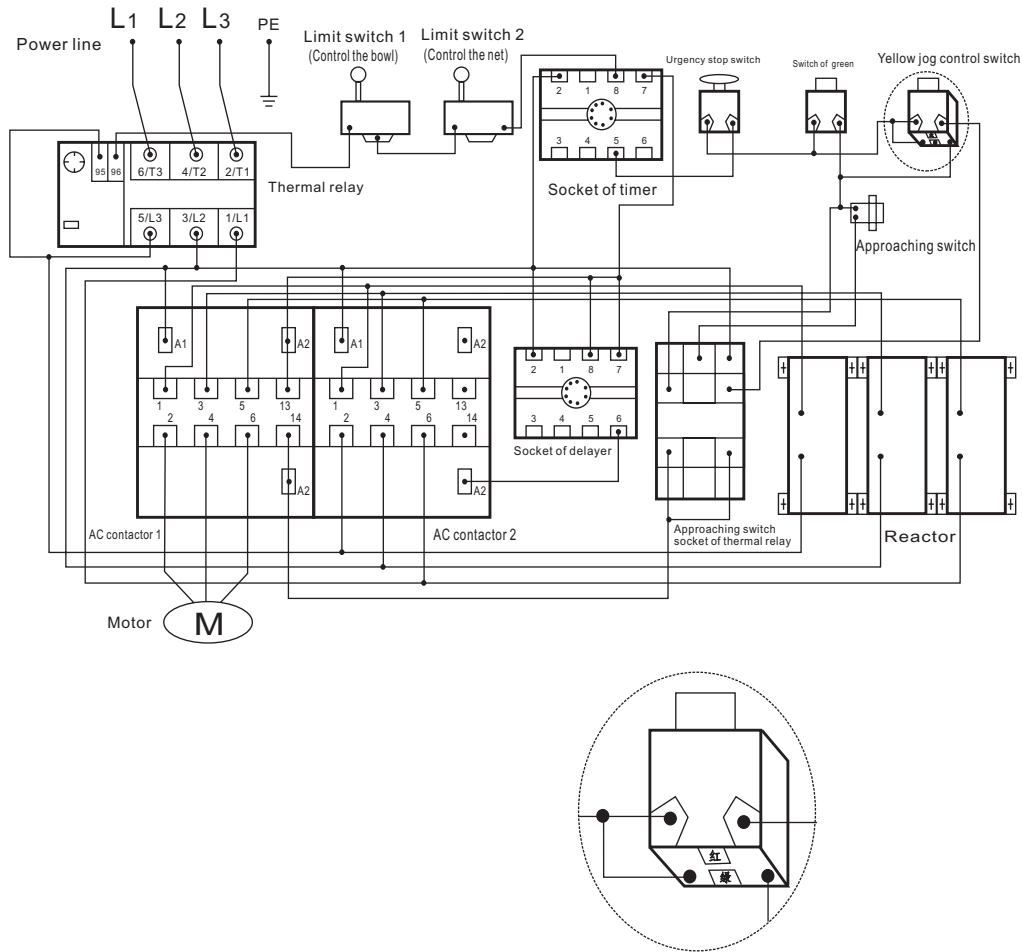

B40K Mixer of multi-function high-speed



B40K MIXER

INDEX

Mixer's dimensions	1
Figure1 Mixer's configuration	2
Figure2 Centre axle	3
Figure3 Gear axle	4
Figure4 Driving axle	5
Figure5 Complete of motor	6
Figure6 Fork and speed axle	7
Figure7 Complete of rise and drop	8
Figure8 Turning plate and mixing axle	9
Figure9 Standard accessories and Technical parameters.....	10
Operation information and breakdown and settlement	11
Warning and special attention	12
Circuit diagram(1)	13
Circuit diagram(2)	14

Circuit diagram (1)
(230V)

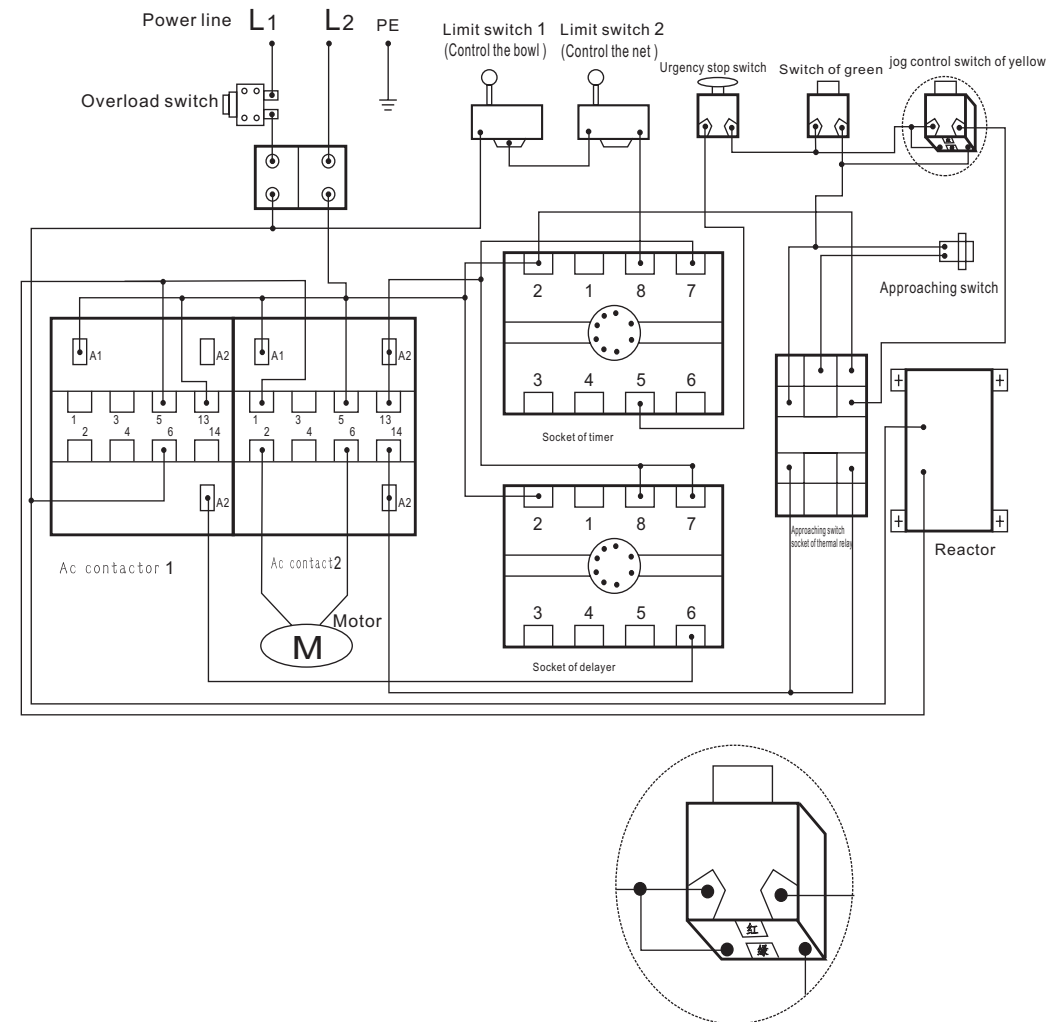

B 4 0 K M I X E R

WARNING AND SPECIAL ATTENTION

WARNING



- Don't rinsing with water pipes.
- Please pull the plug out before maintain the mixer and get maintenance to see to it.
- It's dangerous of touching the electrical switch and power source by wet hand.
- When there are some damages in the mixer, please stop using it.
- There is a ground screw (Signed"⚡"), when the mixer needs to be repairing and be smooth to repair, finally you can not take off the ground wire.
- When the working, don't put your hands into the barrel and don't touching the mixing
- Minors are not allow to close the mixer.
- Mixer must fix on the dry wooden and put the mixer in safety-working zone.
- If the electrical line was broken, please get the profession maintenance to change it.

SPECIAL ATTENTION

- 1、 Before the using, you should clear the dirt away of the barrel and mixing.
When you clear the mixing please carefully. And correct installation of barrel on the fork.
Don't make it tilt.
- 2、 When you choosing the mixing devices, please in according to the nameplate's marked to choosing the correspond speed of, if you choosing wrong, it make the accessory was broken or reduce the mixer's service life.
- 3、 After using, please clear barrel and mixing, then put they in place of safety and clean-zone. Don't forget to cut off the power source.
- 4、 Please keep the dry, public health and safety environment surround the mixer.

B40K MIXER

Mixer' s dimensions

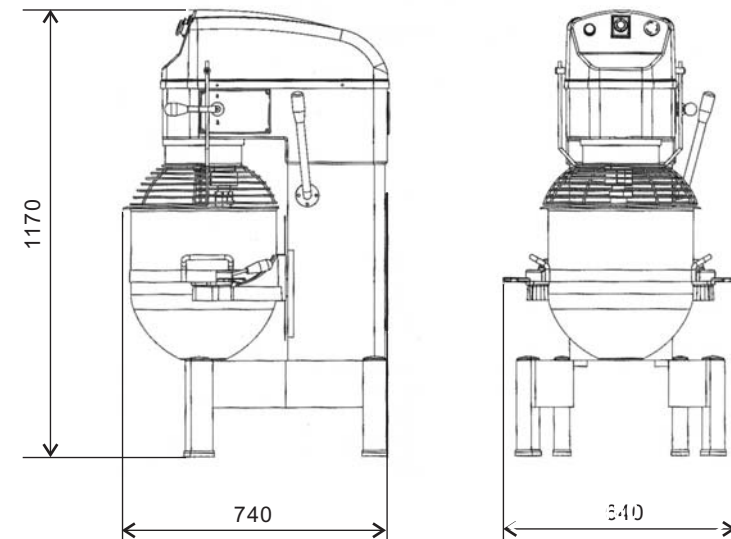

Attention :

- Don't rinsing with water pipes.
- Don't touching the electrical switch and power source by wet hand
- Please pull the plug out before maintain the mixer and get profession maintenance to see to

B40K MIXER

FIGURE 1 Mixer configuration

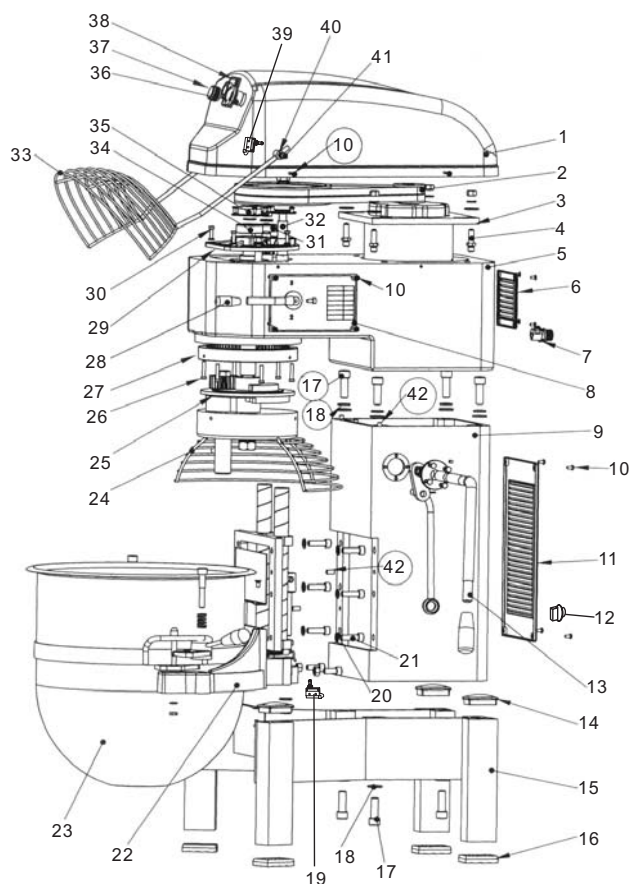

	Accessory's name	Qty
1	Top cover	1
2	Belt of motor SPZ932	2
3	Motor	1
4	Axle of motor	4
5	Gear box	1
6	Vent-window	1
7	Power line	1
8	Name plate	1
9	Column	1
10	Screw M5*12	12
11	Shield of column	1
12	Overload switch	1
13	Handle of rise and drop	1
14	Ruber 1	4
15	Substructure	1
16	Ruber 2	4
17	Screw M14*40	4
18	Spring washer 14	4
19	Switch of rise and drop	1
20	Spring washer 10	6
21	Screw M10*35	6
22	Bracket	1
23	Bowl	1
24	Safety net 1	1
25	Turing plate	1
26	Screw M6*30	6
27	Inner gear	1
28	Ruber	1
29	Cover of bearing	1
30	Screw M6*20	4
31	Gear axle	1
32	Initiative axle	1
33	Safety net 2	1
34	Centre axle	1
35	Avoiding oil cover	1
36	Urgency switch	1
37	Start-up switch	1
38	Timer	1
39	Switch control safety net	1
40	Axle of net	2
41	Screw M8*16	2
42	Pin 8*16	6

Attention :

- We are already imitted enough much lubricated grease, so it can be used for 3 year at normally , but you must change new grease after repairing .
- please tighten up a cover of avoiding grease after change the new grease .

B40K MIXER

Operation information

	► Before using, please check power voltage is suitable for voltage of this mixer or not and the ground wire is firm whether or not
	► Don't install any mixing tool before testing.
	► In according different mixing-material to choose different mixing devices and speed.
	► When the mixer has worked for a long time ,you must cool it down and restart the mixer.
Mixing III	► It is applied to mix liquid, such as cream, eggs, the working time don't more than 15 minuets.
Mixing I	► It is applied to mix mush, powder and smash objects. The working time don't more than 20 minutes.
Mixing II	► It is applied to mix dough and glutinous socover 5-7 kg. The working time don't more than 30 minutes and the dough moisture content at between the 40% to 50%.

Breakdown and settlement

Trouble	Probable cause	Remedy
Mixer can't run after switch on.	It is not good to touch electric.	Check the electric circuit.
Motor is to hot and speed decreases.	Not enough voltage or not suitable for choosing agitator.	Check the voltage or choose suitable position and agitator.
Oil leakage.	The oil seal broken.	Change the new one.
It's hard to raising handle.	Orbit is erosion or the handle's axle and cone gear are dry.	Clean the damaged one and put the lubricate grease.
The mixer's head noise and too hot.	The lubricated grease is not good.	Put in or change grease.
The mixing touches the barrel.	Mixing or barrel change the shape.	Repairing or change the mixing or barrel.
Without high, middle and low-speed output.	The flat key of 7# and figure 4 fret.	Change the flat key of 7# and figure 4.
There're high and middle-speed output without low-speed output.	The spring reed of clutch rupture or the gear ring broken.	Change the accessories.

B40K MIXER

FIGURE 9 Standard accessories

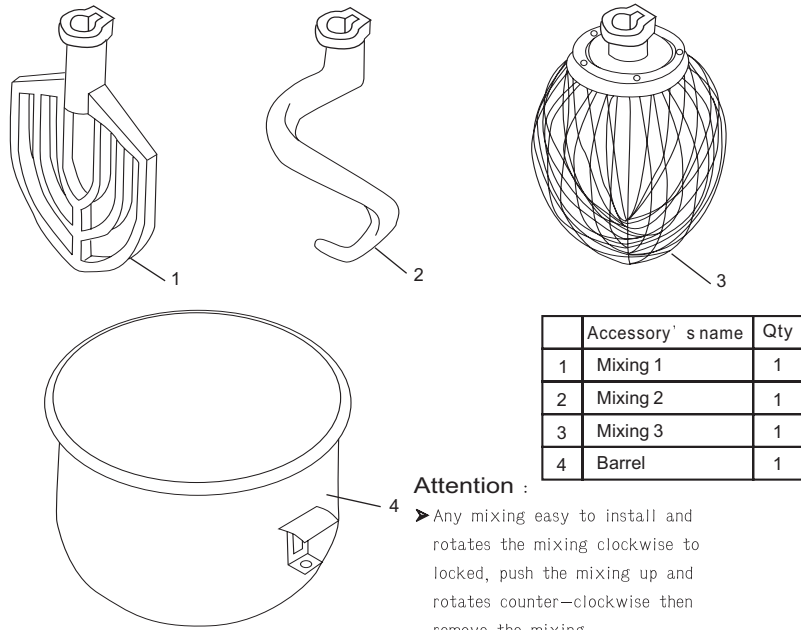

Attention :

➤ Any mixing easy to install and rotates the mixing clockwise to locked, push the mixing up and rotates counter-clockwise then remove the mixing.

Technical parameters

Type	BM40N	BM40N
Safety Guard	Yes	Yes
Mixer (L)	40	40
Rated voltage (V)	230	380
Rated frequency (Hz)	50	50
Rated power input (W)	1300	1300
Mixing speed (r/min)		430
		204
		125
Greatest capacity of dough(kg)	12~12.8	12~12.8

B40K MIXER

FIGURE 2 Centre axle

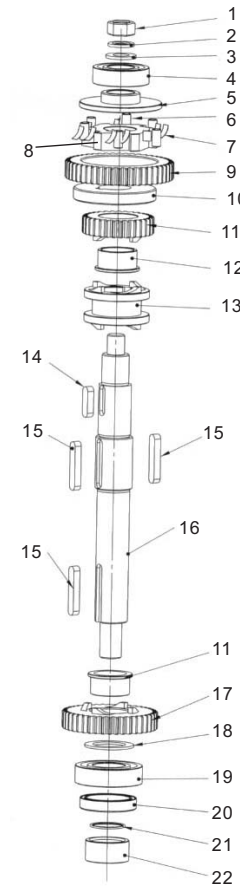

	Accessory' s name	Qty
1	Nut M14	1
2	Spring washer 14	1
3	Washer 14	1
4	Bearing 6205	1
5	Avoiding cover	1
6	Roller 8X16	4
7	Spring	8
8	Clutch	1
9	Gear ring	1
10	Dividing ring	1
11	Small joint gear	1
12	Bearing sleeve	2
13	Joint gear	1
14	Key 8X28	1
15	Key 8X45	3
16	Centre axle	1
17	Big joint gear	1
18	Sleeve of centre axle	1
19	Bearing 6206	1
20	Oil seal 40X52X10	1
21	O ring 30X1.8	1
22	Socket of centre axle	1

Attention :

- After repairing. To ensure installed that the clutch and joint in accordance with the correct diagram.
- If the grease drop from bottom of centre axle ,please check the oil seal whether broken.
- In the demolition or install, due to avoiding the bearing to be broken, you should tap bearing out gently.

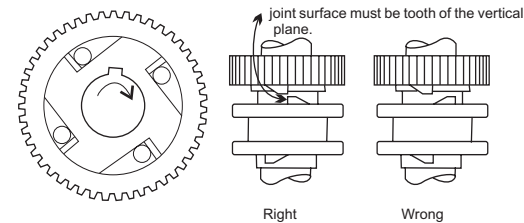
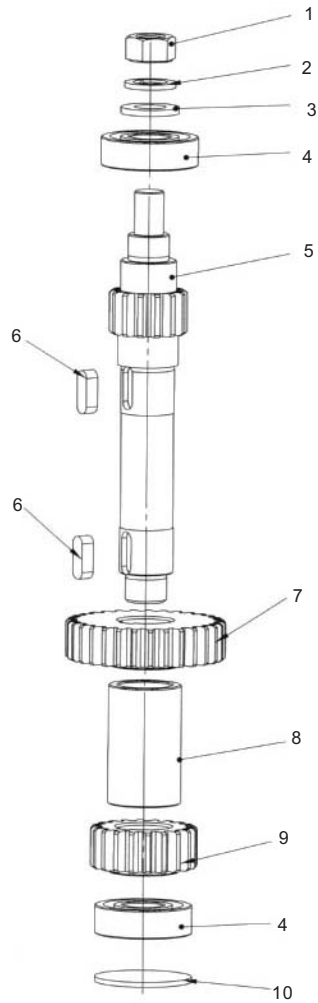

FIGURE 2-1

FIGURE 2-2

B40K MIXER

FIGURE 3 Gear axle



	Accessory' s name	Qty
1	Nut M12	1
2	Spring washer 12	1
3	Washer 12	1
4	Bearing 6203	2
5	Gear axle	1
6	Key 6X18	2
7	High-speed gear	1
8	Sleeve of gear axle	1
9	Low-speed gear	1
10	Gasket	1

B40K MIXER

FIGURE 8 Turning plate and mixing axle

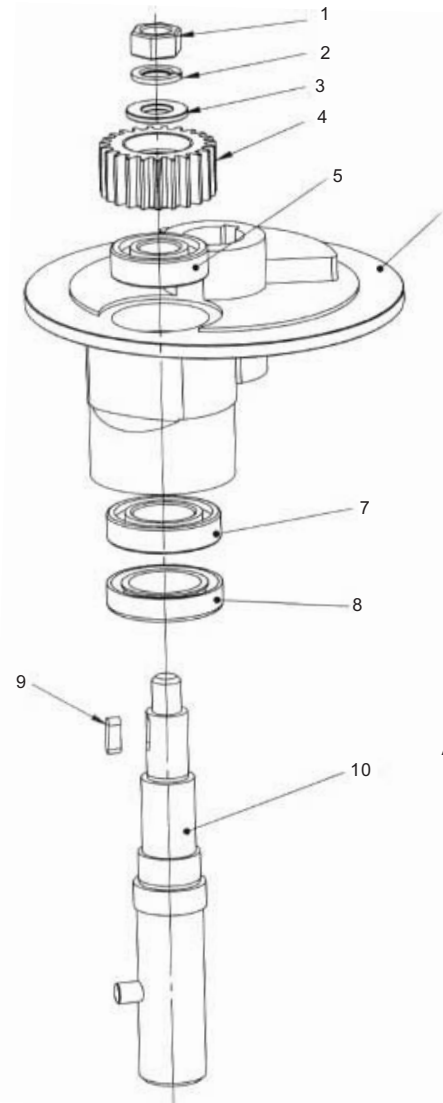

	Accessory' s name	Qty
1	Nut M14	1
2	Spring washer 14	1
3	Gasket	1
4	Planetary gear	1
5	Bearing 6204	1
6	Turning plate	1
7	Bearing 6006	1
8	Oil seal 35*56*12	1
9	Key 6*18	1
10	Mixing	1

Attention :

► When the mixer working ,there is noise with turning plate(8), it's the inner gear(1) was loose. Please pull the turning plate out, then tap at the inner gear and tightening the screw (2).

B40K MIXER

FIGURE 7 Rise and drop of barrel

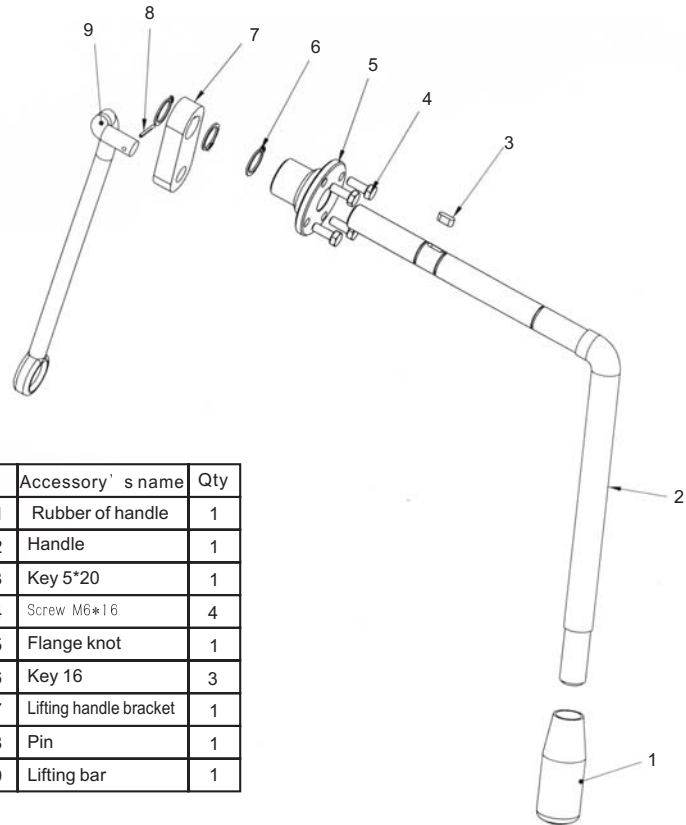

	Accessory' s name	Qty
1	Rubber of handle	1
2	Handle	1
3	Key 5*20	1
4	Screw M6*16	4
5	Flange knot	1
6	Key 16	3
7	Lifting handle bracket	1
8	Pin	1
9	Lifting bar	1

Attention :

- First drop the barrel to bottom, then pull the mixing out, at last take out barrel.
- Put the lubricated grease on the handle axle , the rise and drop pole and cone gear every mouth

B40K MIXER

FIGURE 4 Initiative axle

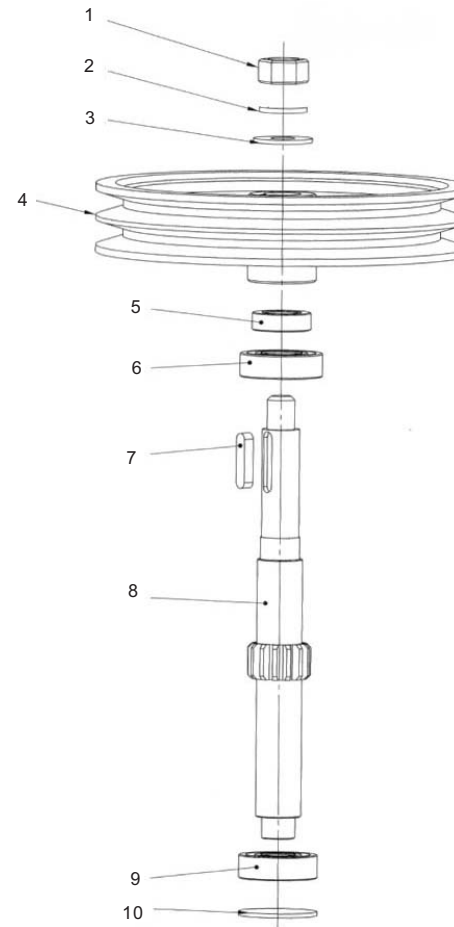

	Accessory' s name	Qty
1	Nut M14	1
2	Spring washer 14	1
3	Washer 14	1
4	Big belt wheel	1
5	Sleeve of belt wheel	1
6	Bearing 6004	1
7	Key 6*28	1
8	Initiative axle	1
9	Bearing 6203	1
10	Gasket	1

B40K MIXER

FIGURE 5 Motor

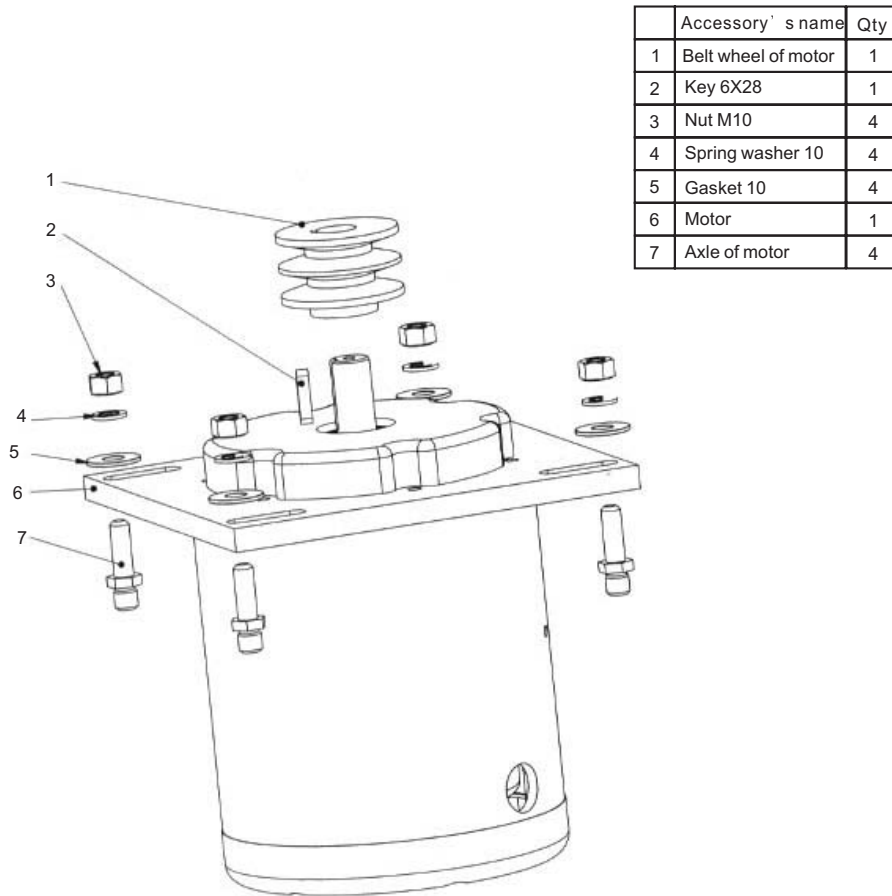

B40K MIXER

FIGURE 6 Fork and change speed axle

