

Hard Ice Cream Machines

User manual

GENERAL INFORMATION

1. Announcement

Our company carries out a continuing research, toward further development and improvement. Therefore, the information found in the manual is subject to change without further notice.

All technical data, pictures and drawings contained in this manual are not binding on the manufacturer, nor can the manufacturer be held liable for any modifications to the machine in whole or in part.

2. Information to the user

For any explanation and information regarding the machine, its spare-parts or how to operate it, the manufacturer of the machine will be available if any questions should arise.

If any problem should occur, please contact our local distributor or the manufacturer if no distributor is available.

3. General data

The equipment applies the technology from several patents that gained, such as the unique evaporation cooling technique and the controlling system of the machine. It is recommended that high quality ice cream mixes should always be used. Always make sure that the mixes is made by high quality raw materials or ingredients from reliable or trustworthy suppliers, so that the over-run rate and taste taken on from this machine can be farthest approved.



Note:

- Always follow the instruction given by the supplier.
- When using the ready-to-use ice cream mixes which goes with stipulated proportion mixing water, do not try to add more water or sugar, since this may lower the quality of the product or disturb the operating condition of the machine.
- Always remember to sanitize the machine after it has been used, and always keep a strict hygiene.
- For best customer satisfaction, always taste the product before serving so you are always sure that you will provide the customer with a first class product.

4. Control Panel Demonstration

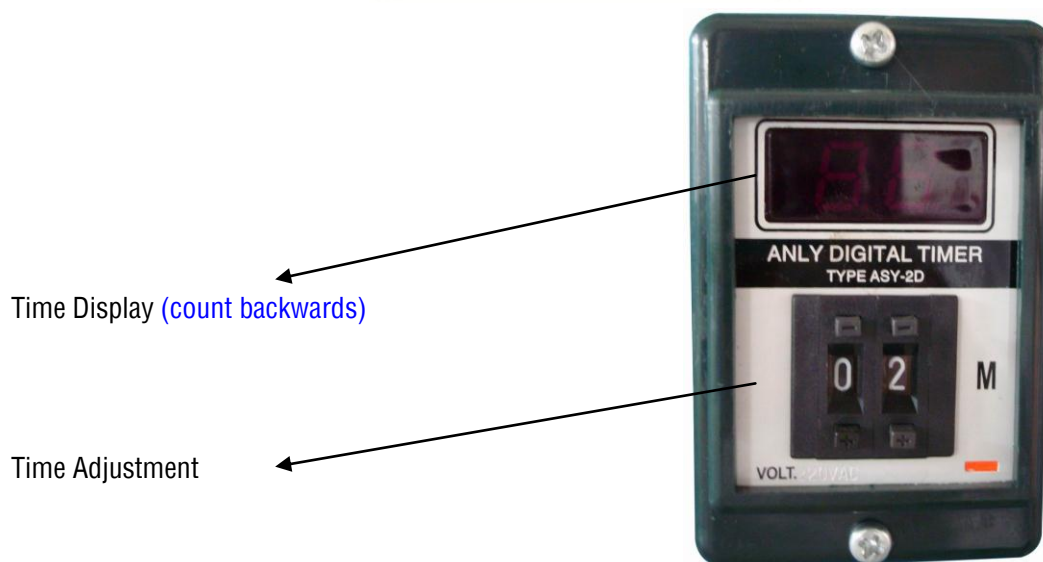
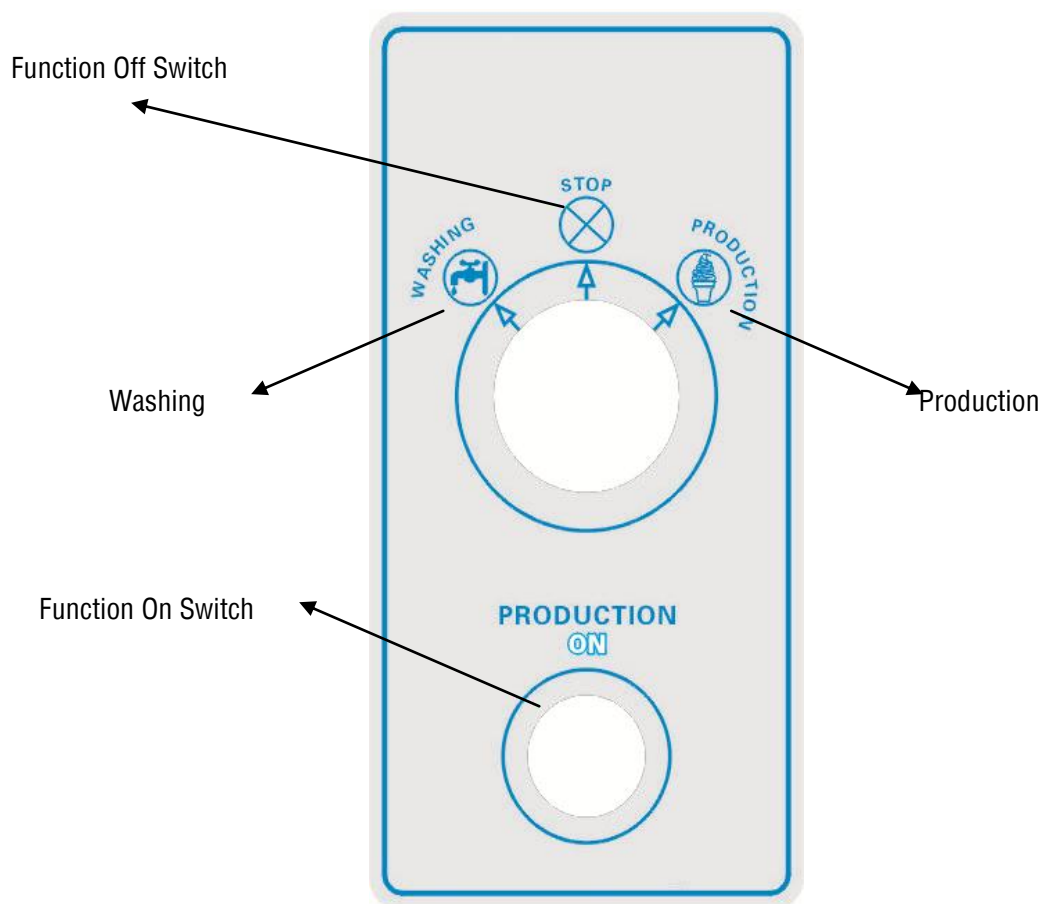

Set up the time from the lower part **TIME ADJUSTMENT**, the upper screen meanwhile shows the correspondent time rate. When the production is started, the time counts back towards zero. As soon as it goes back to zero, the production stops automatically.

5. Operation Condition

The operation requirement for the equipment is as follows:

- Voltage 220 V (190V~245V)
- Operating air temperature 5 °C – 48 °C
- Max relative air humidity 90 %
- Max height above sea level 2000 m
- Normal atmospheric condition

8. Noise

The noise level is normally below 50 dB.

INSTALLATION

1. Room Conditions

The room used for the operation of the hard ice cream machine must be able to provide air that can circulate freely, to prevent over-heating. Therefore the distance from the machine to the wall must be at least 200 mm to the closest wall. It is better to leave no less than 500mm for the ventilation side.

The space where the machine is located should be kept clean, in order to prevent dust or other particles to be sucked into the machine by its fan.

The place where the machine stands should be firm and dry and there should not be any heat sources within 500 mm to the machine.



NOTE: If the minimum room condition is not followed, it may affect the operation of the machine and its output capacity.

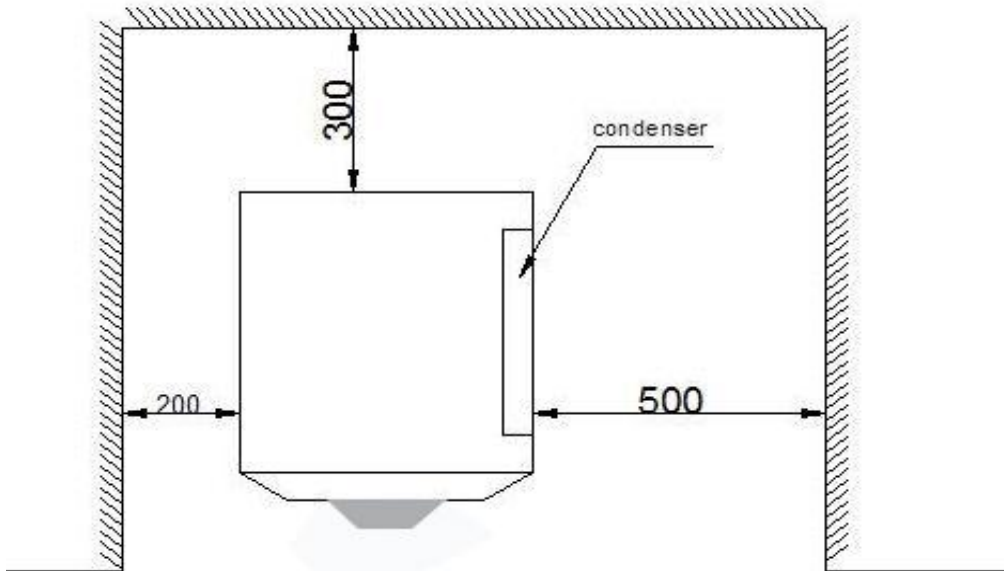

Picture For Instruction Of Machines Placement

2. Electricity Connection

It is of great importance that the power supply to the machine is within the permitted range 190V~245V, with a current capacity above 16 A, also that the machine can be properly grounded. If the voltage should be outside the permitted range, then the machine safety protection will prevent the machine to start and the machine need to be restarted. The cross-section area of the cable that is connecting the machine with its power source should be over 2.5mm^2 and the length shorter than 6m.



Warning:

- if the power cable should of any reason be damaged, a skilled technician with sufficient knowledge and skill should immediately replace it.
- Always ensure that socket of the power source is properly grounded before connecting the machine.

3. Accessories Installation

(1) The feeding Funnel

In order to make the box more tight and make the total volume smaller for more favorable shipping, the feeding funnel is normally separated. To install it is very easy, simply fix the screws while ensuring the trapezium silicon touch well with the edge.

(2) Beater

Wash the beater thoroughly before running the machine. Press the spring plastic beams when putting back the beater into the cylinder. If any spring plastic beam is missing or broken, please do not continue to use the machine. In that case, please contact our servicing department for immediate courier spare parts delivery, and then fix the spring plastic beam back.

OPERATION INSTRUCTION

1. Before The Operation

- (1) Remember to clean the machine and its parts before the first time you start to use the machine.
- (2) Clean the cylinder with towel.
- (3) Washing the visual front door with clean water.
- (4) Be careful to check all silicon parts and ensure they are all in place otherwise it would cause leakage during the production.
- (5) When the accessories are installed well, pour disinfectant into the cylinder from the feeding funnel. Rotates the knob to make it point at **WASHING** for a few minutes. During the process, it is very necessary also to check if the visual front door is well sealed. If any leakage happens, please re-assemble the front door, in order not to affect the real production.

2. Trial Running

After properly installing all the accessories and cleaning the machine, a trial running before ice cream production must be carried out to ensure everything is in good condition.

(1) Rotates the knob to make it point at **WASHING**, the motor starts and the beater rotates via transmission. Rotates the knob to make it point at **STOP**, the motor stops and the beater halt accordingly.

(2) Rotates the knob to make it point at **PRODUCTION**, then press the **ON** command at the lower position, the machine enters into refrigeration mode. The beater motor starting running first while within 10 seconds, the fan, compressor, condenser starts respectively. Hot air is discharged from the ventilation holes on the side panel. The temperature of the chilling cylinder drops down shortly and gradually which turns out to be frosty in no more than one minutes. Rotates back **STOP** button, The whole unit stops.



Caution:

Remove the beater shaft from the chilling cylinder without any ice cream material and the trial running is not allowed for more than 3 minutes because in that case the refrigeration takes too long and the chilling cylinder would be too frosty that might cause damage to the shaft.

3. Ice Cream Production

(1) Pour the ready ice cream mix into the cylinder from the feeding funnel. Please remember not to fill it full, leave 30% empty in order to make enough space for the overrun(ice cream expansion)

(2) Set up the time from the counter, it is suggested to make 15-18 minutes(as per experience that will bear) at the beginning. Then rotates the knob to make it pointed at **PRODUCTION**, press the red **ON** button, the machine starts making ice cream.

(3) Different kind of mix requires different consistency. It is necessary to check the mixing ice cream from time to time, especially when you are not yet too familiar with the machine. To check the mixing ice cream, you can lift up the discharge door to let go a few of the ice cream for your observation. If you think the ice cream is not yet ready, even after the production stops, please re-adjust the counter, add the time for a few minutes and make production working again.

It is also possible to re-adjust the time when the original time is still running. In this case, please first rotate the knob to point at **STOP**. When the machine stops running, press **+** or **-** on the counter to make the time proper.

(5) When you think that the ice cream is ready, lift up the discharge door, the driving force of the beater will push the ice cream out automatically. For those remainder which can not be pushed out, please open the visual door and use spoon get them in order not to waste.

CLEANING & SANITIZING

1. Cleaning

Notice

In order to ensure that the machine is clean, before it is used the first time its parts needs to be sanitized and washed. The cleaning process is also necessary as a daily routine after ice cream production has been done or if the machine has not been used for a long time.



WARNING:

Before disassembling any parts, always remember to stop and unplug the machine.



IMPORTANT:

Because this is a food-producing machine, always remember to keep good hygiene and to wash and sanitize all parts that have been in contact with the product after the machine has been used.

After the cleaning process is done then the parts should be rinsed with bacteria- free drinking water and thereafter dried.

The temperature of the **water** used during cleaning, should never exceed **40 °C** since it may cause damage to the plastic parts and seal in the machine.



INFORMATION

To prepare sanitizing solution you need to:

1. Fill a 5 L container with water.
2. Pour one bag of sanitizer into the water.
3. Mix the solution for 2 minutes or until all the sanitizer is dissolved.
4. The sanitizing solution is ready to be used.

2. Daily cleaning

Mildew and bacteria can thrive and multiply rapidly in fat mixture contents, therefore cleaning and sterilizing must be carried out as above mentioned with utmost care.

All stainless steel materials used for parts in contacts with mixture and ice cream are easy to clean but do not prevent the proliferation of mildew if not cleaned sufficiently.

- (1) Sanitize and clean the cooling cylinders
- (2) Sanitize and clean the discharge door and beater



Caution:
Too hot water could damage the special materials of the machine such as the silicon gasket.

3. Sanitize and clean the beater assembly

- (1) Pour water into the cylinder while the visual door is fixed on, be sure the water is enough for cleaning.
- (2) Rotate to **WASHING**, the beater runs strongly for self-cleaning. After a few minutes, rotate to **STOP** to turn off the beater. Then lift up the discharge door slowly to pour out the dirty water. (When the remainder is mostly cleared or dissolved, you can also get the beater out to a water tank for further hand-washing)

4. Clean the machine shell with a cloth drenched in a sanitizer.

5. Clean the drip tray and drip pan with water and sanitizer.

TROUBLESHOOTING

1. Analysis table (1)

Problems	Reason	Possible Causes	Solutions Suggested
Refrigeration Is Disable	1.The compressor does not run	A. The starter or capacitor breaks down. B. The overload protection is defective C. Power voltage is too low or the section area of the electric cable is too narrow that it causes low voltage.	A.B. Change the new ones C. Contact the local power supply station for more details or match a unit of regulator. Change a new cable for a large section if it is caused by the cable.
	2.The chilling system is blocked by ice	Moisture exists	Clean up the moisture
	3. Leakage of refrigerant gas	The chilling system is not completely/properly sealed.	Check up the leakage and repair accordingly by vacuumizing and refilling refrigerant gas.
Ice cream is not hard enough or takes too long to be finished	Refrigeration is too weak	A. Refrigerant gas is lacking(not enough) or not re-filling enough. B. The machine has been used for a long time. The leakage is over normal annual volume.	Refill the refrigeration system with the corresponding gas type. The volume to be refilled must comply with the amount indicated on the compressor plate sheet. Repair the leakage before refilling

	Improper evaporating temperature of the refrigerating	The thermal expansion valve is not properly adjusted	Adjust the valve so that the evaporating temperature to make it in best state.
--	---	--	--

2. Analysis table (2)

Problems	Reason	Possible Causes	Solutions Suggested
Leakage of the ice cream stuff or water	1. Leakage from visual front door	A. The large O-ring sealing is not properly installed, or not well in location, or has been already defective.	Change some new g sealings.
	2. Leakage from the discharge door	The silicon sealing is defective or broken down	Change new sealing
The ice cream is not able to discharged.	The ice cream is too hard	<p>A. The ice cream material involves too much proportion of sugar</p> <p>B. Improper overload proof adjustment</p> <p>C. The production time is too long and that the ice cream is too frozen</p>	<p>A. Use the ready-to-use material from good supplier or adjust the proportion of recipe</p> <p>B. Turn to the professional repair man for the adjustment of the overload proof</p> <p>C. Shorter the production time before starting the production.</p>

	The mixer shaft does not rotate	A. Motor is broken down B, The control circuit is defective C. The transmission belts are too loose. D. The gear box is defective.	Repair or change the damaged parts
--	---------------------------------	---	------------------------------------