

Popcorn Machine

User manual

Please read this manual before usage.

A. Function and features:

The popcorn machine combines all the advantages of the popcorn machines both in and abroad. It is made of aluminum alloy and toughened glass, with a sprayed inattentive interior coat. The machine also has the features of cleanliness and sanitation, easy cleaning, simple and safe operation and saving energy, which is fit for restaurants, snack bars, cinemas and so on.

B. Specifications:

C. Transportation and Storage

| MODEL | TT-P3 | TT-P4 | TT-P1 | TT-P6B |
|-----------------------|-------------|-------------|-------------|-------------|
| Power (V) | 220V~ | 220V~ | 220V~ | 220V~ |
| Output (kW) | 1.42 | 1.42 | 1.44 | 1.44 |
| Frequency (Hz) | 50 | 50 | 50 | 50 |
| Temperature (°C) | 220~270 | 220~270 | 220~270 | 220~270 |
| Formal Size (mm) | 500x360x650 | 550x440x730 | 500x410x790 | 500x410x790 |
| Casing Size (mm) | 540x420x710 | 590x460x780 | 550x460x820 | 550x460x820 |
| Oil Dosage (ml/once) | 50 | 50 | 50 | 100 |
| Sugar Dosage (g/once) | 100 | 100 | 100 | 200 |
| Corn Dosage (g/once) | 150 | 150 | 150 | 300 |
| Efficiency (pan/min) | 1/2 | 1/2 | 1/2 | 1/2 |

When being transported, be careful not to shake the machine violently; don't put it outdoors or in the direct sunlight. If so, avoid rainfall; Store it in ventilated places out of erosive

gases; Don't put it up-side-down.

D. Cautions:

1. The machine should be laid up flat and stable.
2. The machine must be used together with the suitable power source suggested by the factory, that power±10%(V).
3. Suitable switch, fuse box and the leak electricity switch should be fixed near the machine, without piled up rubbish to make it convenient to operate.
4. The ground wire and the power source wire should come from the same place, connected with a safe three-pin plug in the outlet.
5. All the connection with electricity should be done by the qualified electrician
6. This equipment is not equipped to be used by unwell, unresponsive or mentally disturbed people, including children, unless under the guidance or help of persons who are responsible for their security. Keep an eye on children and keep them away from playing around the equipment.

7. Measures should be taken to prevent the equipment from falling off in case it is put on a stander.

E. Operation

1. Turn on the switch of heat preservation to start the heat tube and light.
2. Turn the heating knob to preheat the plate for 5~6 minutes.
3. First, you should put about 50ml esculent oil in boiler, then put some corn (import or domestic) and sugar (non-burnt sugar) in it until the oil is heated up to fume and close the movement door. You can hear voice at first, at the approach of the end, the popcorn will overflow the boiler. Twist the handle clockwise, the boiler is unilateral and the popcorn could be spill out, the method is: twist the handle counter clockwise, the broiler will perfect inversion and the popcorn could be spill out fully.
4. Pay attention to the corn while popping in case it will be burnt. Close the door firmly so that the corn can not come out.
5. Stir the corn until it is all burst open, then pour it out from the plate.
6. Repeat 1~5 to make more popcorn. It needs only 2 minutes to pop the corn continuously.
7. Do not drop any oil around the plate. Otherwise it will catch fire when it is heated to a certain temperature.

NOTICE: To avoid dangers caused by accidentally wrong restoration of the thermal circuit breaker, don't supply power to the equipment with an exterior device of switches, like timers, nor connect it to a circuit which is connected or cut off regularly by universal parts.

Warning: Do not add any water to the plate while it is popping!

F. Electric theory

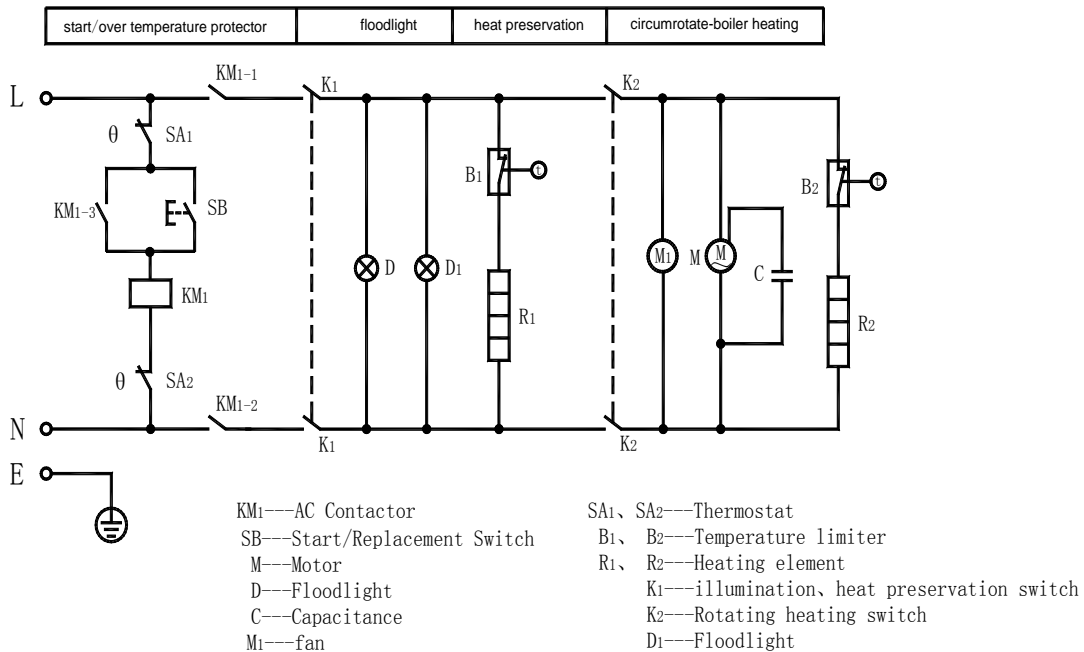

G. Cleanliness and Protection:

1. Cut off the electricity power and pull out the plug to avoid accidents when you clean the machine.
2. machine.
3. Use the wet towel with some anticorrosive detergent to clean the outside parts of the machine. Do not clean the machine directly with water. Otherwise the electric function will be damaged.
4. If it is not used for a long time, you should cut off the electricity and pull out the plug.
5. Do not brush the inside part of the plate with hard metal. Otherwise you will damage the coat.

Warning: Don't clean the machine by using steam cleaner.

H. Troubleshooting guides:

| Sequence | Problem | Causes | Possible remedies |
|----------|---------------------------------|--|---|
| 1 | Light not on | Not plugged in outlet | 1. fasten the screw of connecting the wires 2. change the light bulb |
| 2 | Can not heat | 1. loose in wire of the heated tube 2. heated tube burnt 3. broken electric capacity | 1. fasten the screw from which the wires come out. 2. change the heated tube. 3. change the electric capacity |
| 3 | Too high or too low temperature | Broken thermostat | Change the thermostat |

Appendix to the machine: 1. an operation manual
2. A bulb