

B20F/B20F4/B30F4

MIXER USER MANUAL

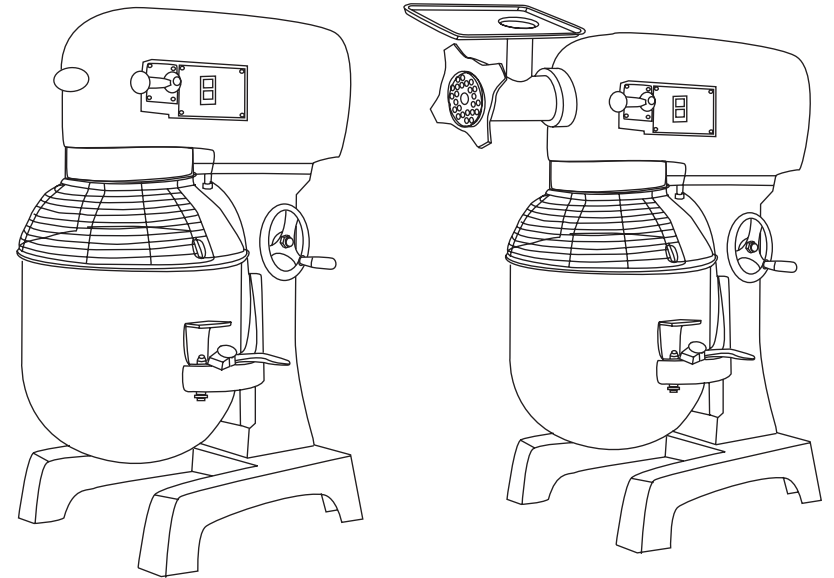

ELECTRIC DIAGRAM

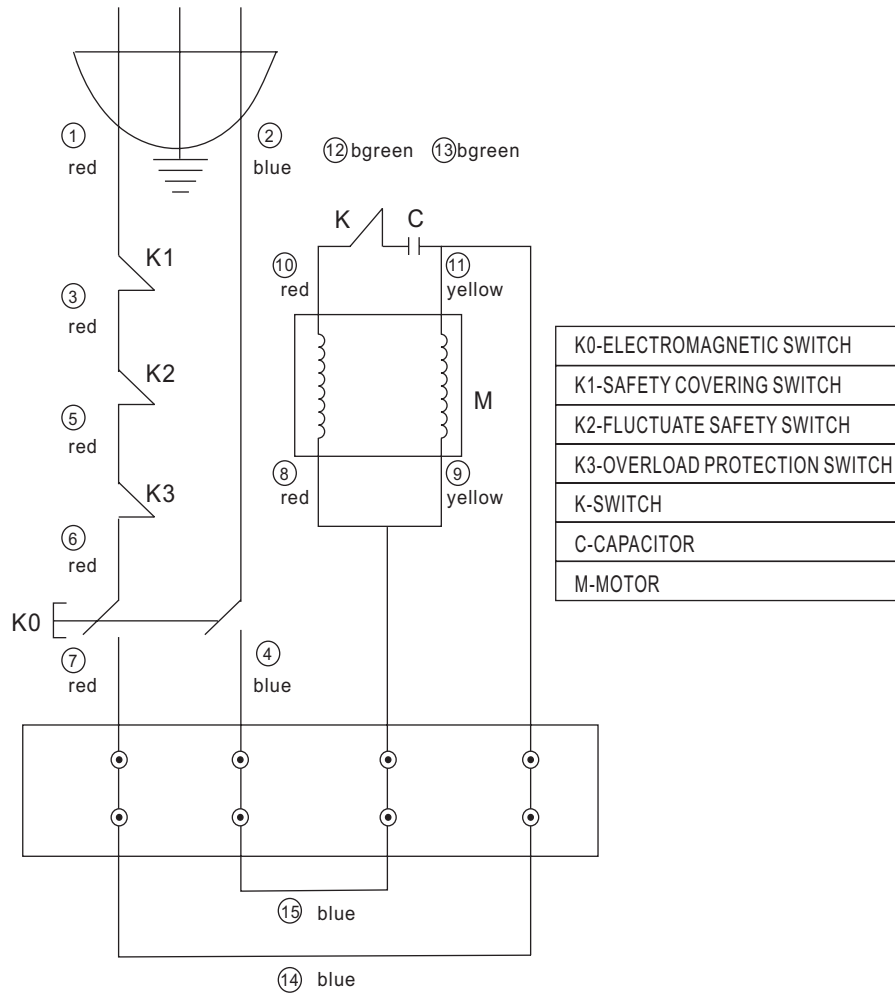

INDEX

PARTS CATALOG OVERVIEW 1

FIGURE 1 TRANSMISSION CASE 2

FIGURE 2 AXLE 3

FIGURE 3 GEAR AXLE 4

FIGURE 4 GEAR AXLE I 5

FIGURE 5 MOTOR UNIT 6

FIGURE 6 FORK AND SPEED SHAFT 7

FIGURE 7 MACHINE SEAT, STAND AND BOWL LIFTER UNIT 8

FIGURE 8 TURNING PLATE AND MIXING AXLE 9

FIGURE 9 MEAT GRINDER 10

FIGURE 10 STANDARD ACCESSORIES 11

OPERATION INSTRUCTION 12

WARNING AND SPECIAL ATTENTION 13

TROUBLE SHOOTING AND SPECIFICATION 14

ELECTRIC DIAGRAM 15

B20F/B20F4/B30F4 Mixer Parts List

PARTS CATALOG OVERVIEW

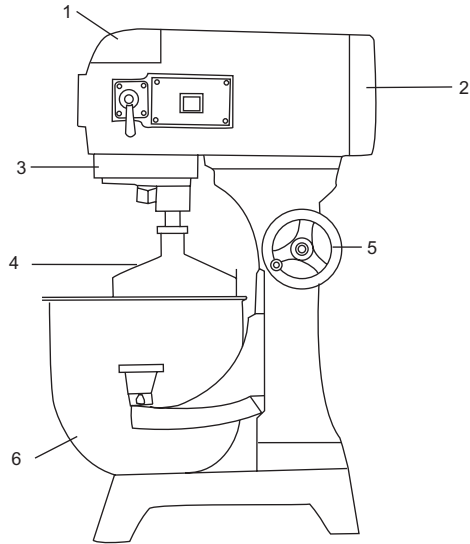

Item	Description
1	cover
2	rear cover
3	ring
4	Mixing device
5	french
6	bowl

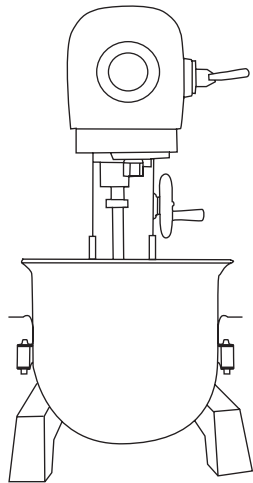

NOTES:

- The no using pipe line sprays to wash the mixer.
- Wet hand in no using contact switch with power supply plug.
- While maintaining the mixer, must pull out first the power supply plug, and from profession the personnel maintains.





B20F/B20F4/B30F4 Mixer Parts List

TROUBLE SHOOTING AND SPECIFICATION

TROUBLE SHOOTING

Trouble	Possible Causes	Re-cover
The axle can't work when operate the machine.	Poor contact of the electrical equipment.	Check the plug.
The mixing bowl out of position.	Moving direction is not correct.	
Leak oil.	Sealing washer is damaged.	Change.
Defficult to move the bowl up and down.	Slideway is rusted.	Clean the slideway and lubrication.
The motor is overheat and speed down.	The voltage is not enough, or incorrect speed.	Check the voltage or use lower speed.
Noise and over heat.	Poor lubrication.	Add or change lubrication.
Mixer touch the bowl.	The mixing device or bowl deformed.	Repair or change the bowl or mixing device.

SPECIFICATION

Type	B20F	B20F	B20F4	B20F4	B30F4	B30F4	
Mixer (L)	20	20	20	20	25	25	
Power Supply (V)	110~	220-240~	110~	220-240~	110~	220-240~	
Input Power (W)	1100	1100	1100	1100	1500	1500	
Mixing Speed (r.p.m)		548	462	497	418	497	418
		376	317	278	234	278	234
		208	197	154	130	154	130
				163/91/50	163/91/50	163/91/50	163/91/50
Maxflour Capacity(kg)	5	5	5	5	6	6	

B20F/B20F4/B30F4 Mixer Parts List

WARNING AND SPECIAL ATTENTION

WARNING

- 1 DON'T USE WATER PIPE TO WASH THE MIXER DIRECTLY;
- 2 PLEASE PULL OFF THE PLUG BEFORE MAINTAINNING, AND MAKE IT MAINTAINED BY PROFESSIONALS;
- 3 DON'T TOUCH THE SWITCHS AND PLUG WITH WET HAND;
- 4 IF BROKEN, PLEASE STOP USING AT ONCE
- 5 THERE IS A GROUNDED NUT (SIGNED " \perp ") IN THE MACHINE, PLEASE RECOVER IT TO ORIGIN CONDITION, DON'T CANCEL THE GROUNDED LINE;
- 6 DON'T PUT HANDS INTO THE BOWL OR TOUCH THE MIXING DEVICES WH-EN WORKING;
- 7 DON'T ALLOW THE MINOR CLOSE TO THE MACHINE;
- 8 THE MACHINE SHOULD BE FIXED ON THE DRY WOODEN SPLINT AND WO-RK IN SAFE AREA;
- 9 IF THE ELECTRICAL WIRE IS BROKEN, PLEASE CHANGE IT BY PROFECTIONALS.

SPECIAL ATTENTION

- 1 BEFORE USING , PLEASE CLEAN THE BOWL AND THE MIXING DEVICES CAR- EFULLY, AND THEN INSTALL THE BOWL ONTO THE MACHINE CORRECTLY AND TIGHTLY;
- 2 WHEN CHOOSING MIXING DEVICES, PLEASE REFER TO THE OPERATION MA- NUAL TO CHOSE THE CORRECT SPEED, OR IT WILL DESTORY THE INSIDE SPA- RE PARTS AND SHORTEN THE USING LIFE OF THE MACHIE;
- 3 AFTER USING, PLEASE POWER OFF THE MACHINE, AND PUT THE BOWL AND DEVICES IN THE SAFE AND CLEAN PLACE AFTER CLEANING;
- 4 KEEP ENVIROMENT ARROUND THE MACHINE DRY、HEALTH AND SAFE.

✳ In order to keep safety, when using Mixing device I/II/III , Please pay attention to insert their grooves which are from the handles into the spiral axle pin separately. Furthermore, rising the bowl to the highest positon, so that the edge of the bowl is higher than Mixing device I/II/III working position.

B20F/B20F4/B30F4 Mixer Parts List

Figure 1 TRANSMISSION CASE

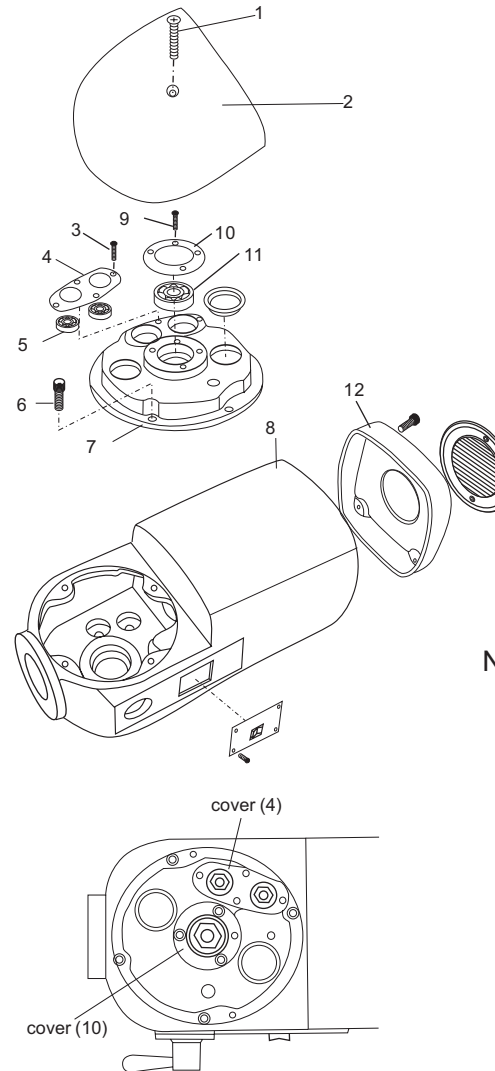

Item	Description	Qty
1	screw M6*45	1
2	cover	1
3	screw M5*8	4
4	cover	1
5	bearing 6201	2
6	screw M6*25	4
7	end cover	1
8	body	1
9	screw M5*8	3
10	cover	1
11	bearing 6003	1
12	rear cover	1

NOTES:

- Machine at a factory hour have added to note the superior quality lubricates the grease, usually the circumstance bottom can use for several years, but machine is after maintaining, must replace the lubrication grease.
- Fill with the lubrication grease empress, please the cover the tight noting the oil bore cover.

B20F/B20F4/B30F4 Mixer Parts List

Figure 2 AXLE

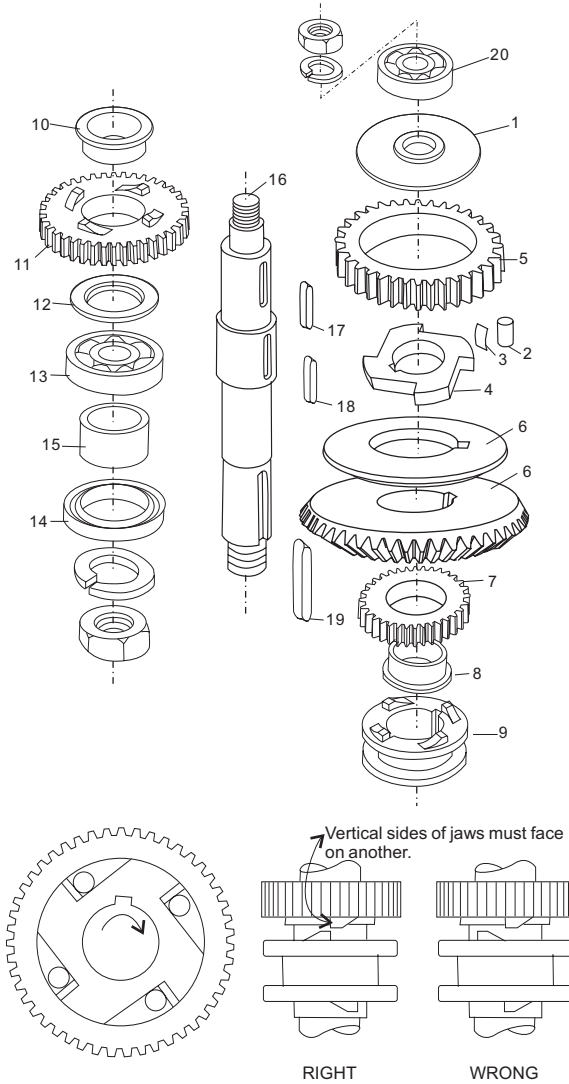

FIGURE 2-1

FIGURE 2-2

Item	Description	Qty
1	baffle	1
2	roller $\varnothing 8 \times 16$	4
3	spring	4
4	engager	1
5	gear ring	1
6	dividing ring(B20F)	1
	horizontal taper gearing(B20F4)	1
7	joint gear	1
8	bearing ring	1
9	joint	1
10	bearing ring	1
11	joint gear I	1
12	ring	1
13	bearing 6205	1
14	oil seal Pd30*45*10	1
15	sleeve	1
16	axle	1
17	key 6*15	1
18	key 6*34	2
19	key 6*30	1
20	bearing 6003	1

NOTES:

- ▶ Be sure to install correct position (see Figure 2-1) and lubricate all of the pins in the sleeve drive when reassembling.
- ▶ Joint (9) must always be raised and lowered smoothly. Be sure joint sleeve as shown in Figure 2-2.
- ▶ Check oil seal (14), if serious oil leaks from drip cup.

B20F/B20F4/B30F4 Mixer Parts List

OPERATION INSTRUCTION

		<p>▶ Before using, please check power supply if it match your machine and be sure ground wire is eliable.</p>
		<p>▶ Before testing, please take mixing device off first, in order to avoid damage machine which is match moving direction. It's necessary to change the three-phase machine if the moving direction is not match with arrow.</p>
<h1>OFF</h1>		<p>▶ For changing the speed: Please stop machine first before change speed in order to avoid damage gear box.</p>
		<p>▶ Mixing: according to the different mixing-material. Choose the different mixing devices and speed.</p>
A		<p>▶ A: Be suitable for mix and stir butter, eggs, and work with in high speed, working time is less than 15 minutes.</p>
B		<p>▶ B: Be suitable for mix and stir stuffing and raw material, and work in middle speed, working time is less than 20 minutes.</p>
C		<p>▶ C: middle position is suitable for mixing dough, working time is less than 30 minutes. Flour water quantity is 40%-50%.</p>

B20F/B20F4/B30F4 Mixer Parts List

Figure 10 STANDARD ACCESSORIES

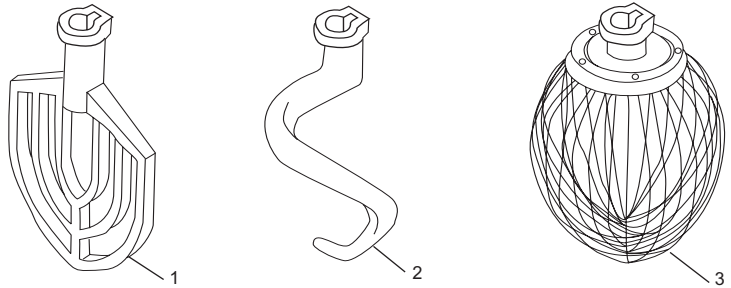

Item	Description	Qty
1	Mixing device I	1
2	Mixing device II	1
3	Mixing device III	1
4	bowl	1

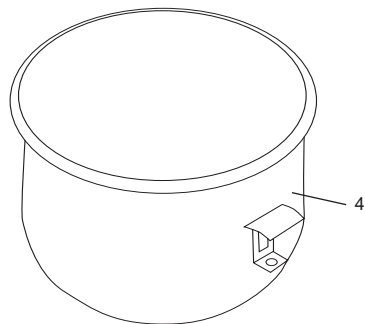

NOTES:

- Any agitator is easily installed by simply raising it onto the mixing axle, and then rotating it clockwise on the shaft until into place. To remove, raise the agitator on the shaft until it clears the lock and then rotate counter-clockwise and lower.
- All of tools are precisely fitted to the bowl, rounded corners and easily removable for cleaning.

B20F/B20F4/B30F4 Mixer Parts List

Figure 3 GEAR AXLE

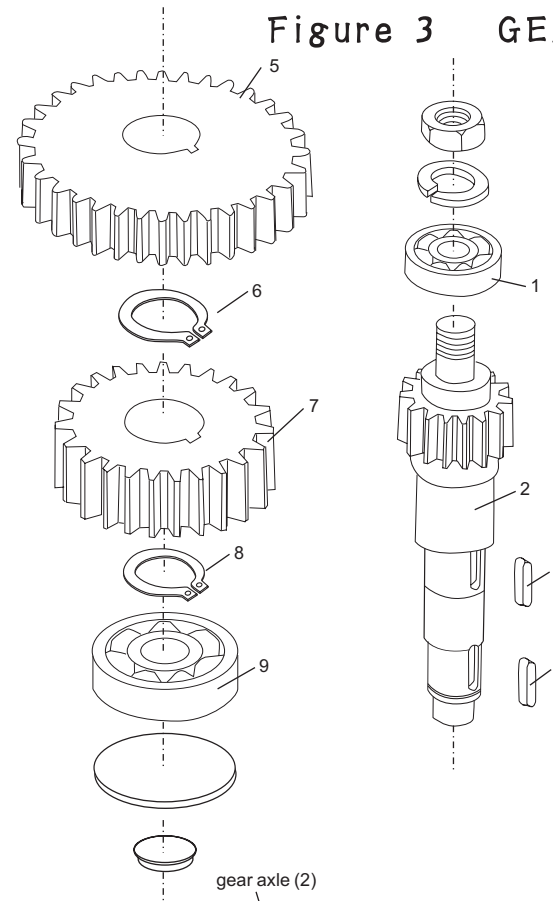

Item	Description	Qty
1	bearing 6201	1
2	gear axle	1
3	key 5*11	1
4	key 5*11	1
5	gear	1
6	stop ring	1
7	gear	1
8	stop ring	1
9	bearing 6201	1

NOTES:

- At the center in the shaft unit. To the above is the gear shaft and gear shaft I (see figure 3-1).
- C-type stop ring(6/8) has to be fixed when reassembling.
- Be sure that the keys are inserted for each gear.

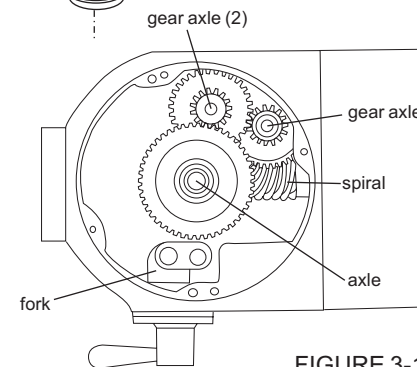
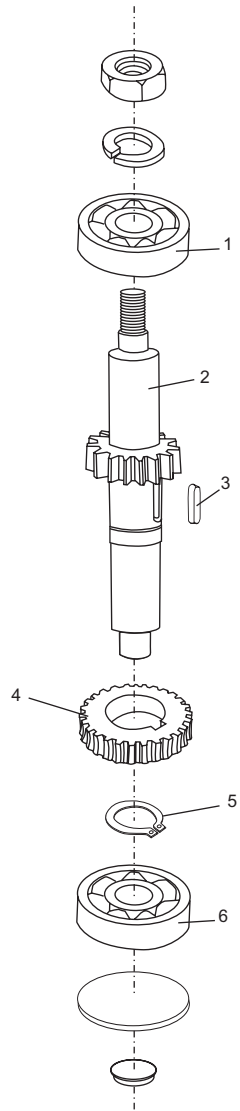

FIGURE 3-1

B20F/B20F4/B30F4 Mixer Parts List

Figure 4 GEAR AXLE I



Item	Description	Qty
1	bearing 6201	1
2	gear axle	1
3	key 5*14	1
4	gear	1
5	stop ring	1
6	bearing 6201	1

NOTES:

- C-type stop ring(5) has to be fixed when reassembling.

B20F/B20F4/B30F4 Mixer Parts List

Figure 9 meat grinder
(B20F4)

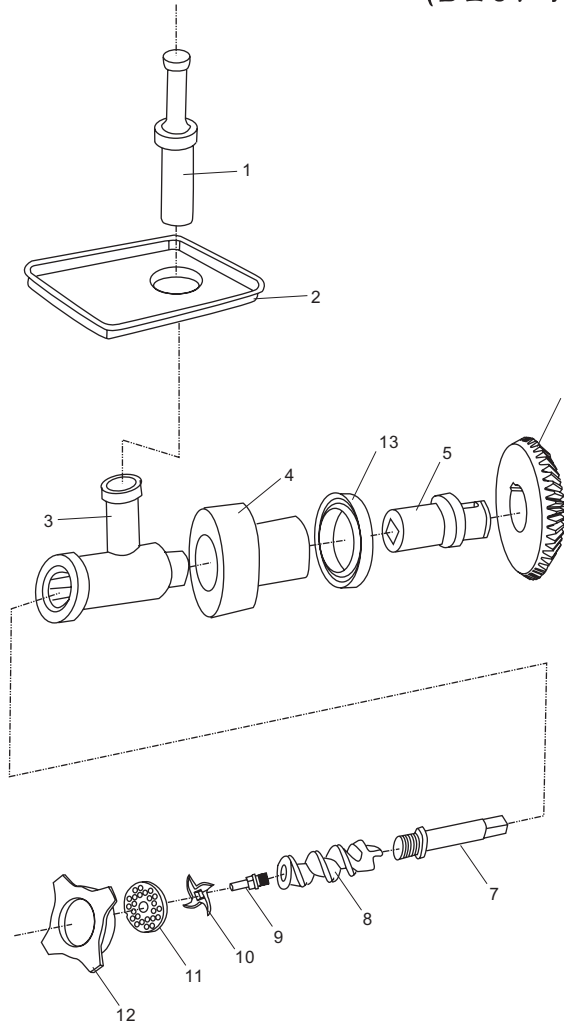

Item	Description	Qty
1	fill the meat stick	1
2	meat dish	1
3	cutting head	1
4	flange	1
5	transmission shaft	1
6	vertical tapered gear	1
7	pusher shaft	1
8	pusher	1
9	transmission core	1
10	cutter	1
11	meat out plate	1
12	rounded nut	1
13	oil seal pd30*45*10	1

B20F/B20F4/B30F4 Mixer Parts List

Figure 8 TURNING PLATE AND MIXING AXLE

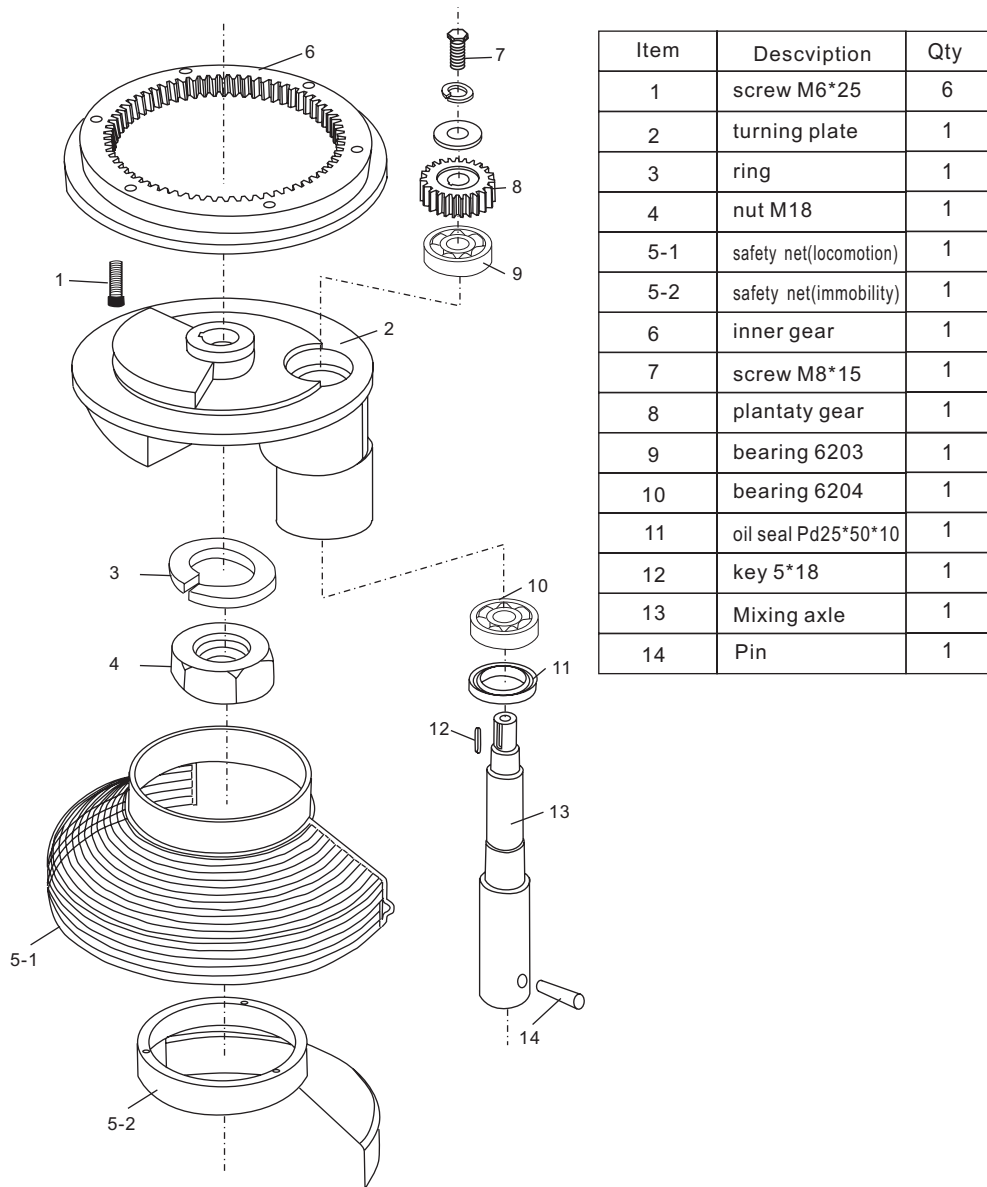

B20F/B20F4/B30F4 Mixer Parts List

Figure 5 MOTOR UNIT

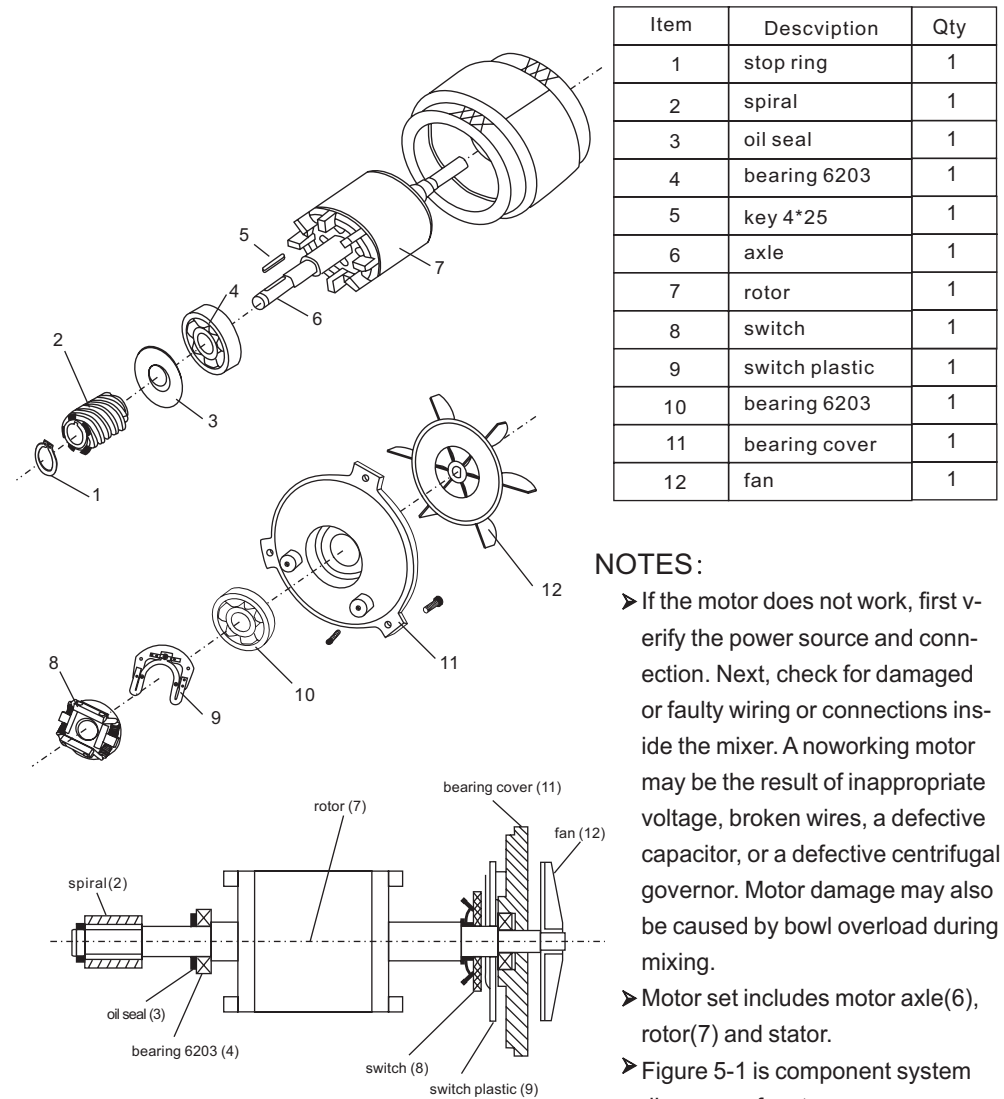

FIGURE 5-1

B20F/B20F4/B30F4 Mixer Parts List

Figure6 FORK AND SPEED SHAFT

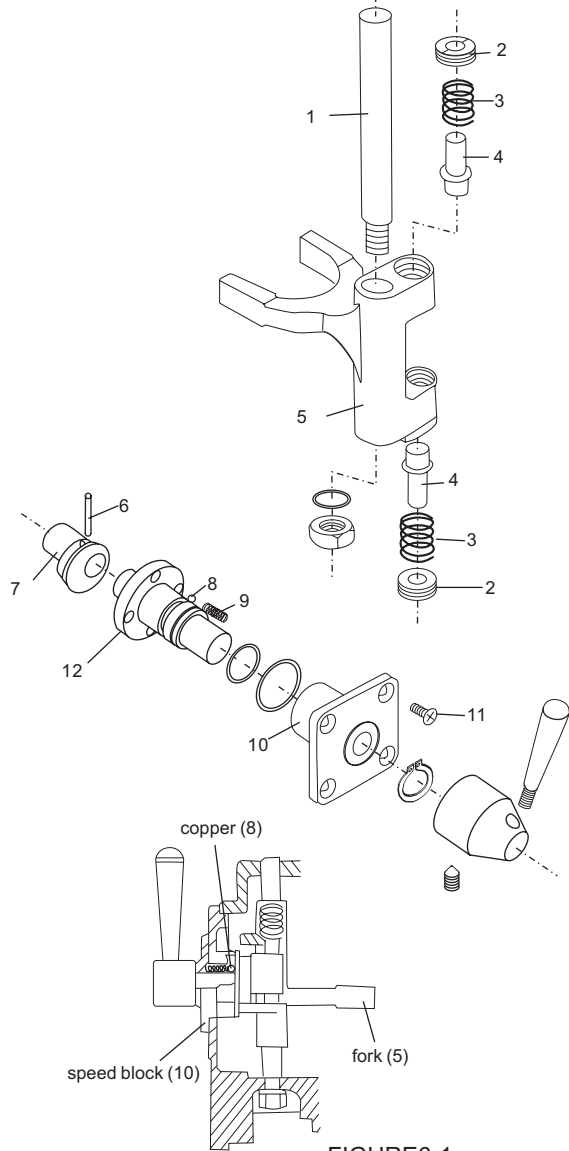

FIGURE6-1

Item	Description	Qty
1	axle	1
2	nut	1
3	spring	1
4	shaft	1
5	fork	1
6	pin 4*25	1
7	eccentricity knot	1
8	steel ball	3
9	speed spring	3
10	speed block	1
11	screw M5*10	1
12	shaft	1

NOTES:

- ▶ The speed selector / shifting mechanism is designed for simplicity and reliability. It features three mixing speeds.
- ▶ Speed selection is made by aligning the pointer of the shifter handle with the proper number on the shift selector. Stop the mixer before making any speed changes.
- ▶ Apply sealant to the shift selector assembly, and install it.

B20F/B20F4/B30F4 Mixer Parts List

Figure 7 MACHINE SEAT, STAND AND BOWL LIFTER UNIT

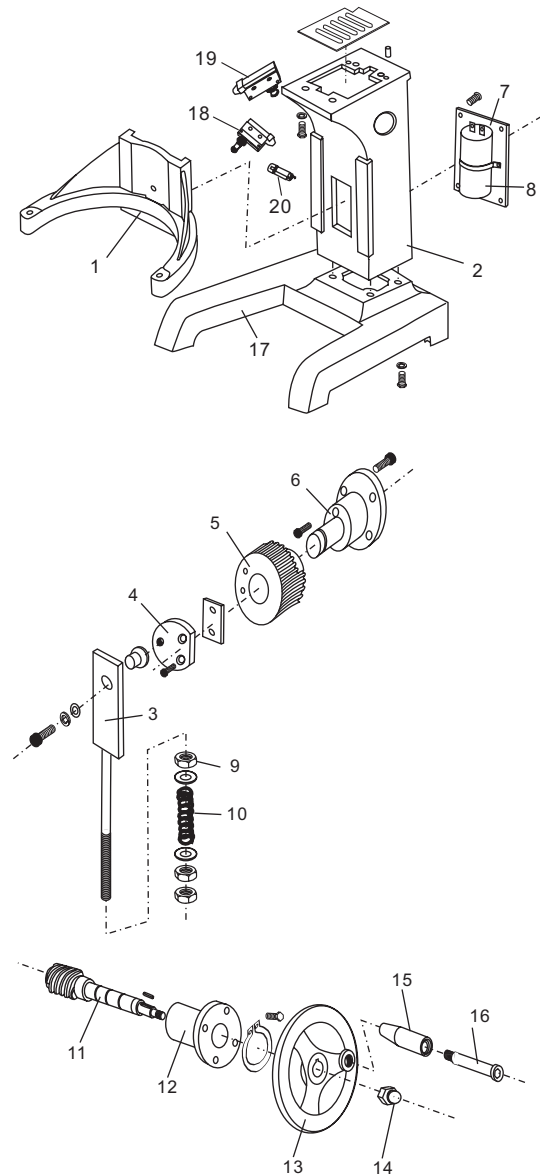

Item	Description	Qty
1	arm	1
2	stand	1
3	slide	1
4	plate	1
5	gear	1
6	support seat	1
7	capacitor board	1
8	capacitor 200uF	1
9	nut M10	3
10	spring	1
11	spiral	1
12	french support	1
13	handwheel	1
14	nut M10	1
15	handle	1
16	handle screw	1
17	machine seat	1
18	safety covering switch	1
19	fluctuate safety switch	1
20	overload protection switch	1