

ELECTRIC FRYER

USER MANUAL

I. PLEASE KEEP THIS MANUAL FOR FUTURE REFERENCE

Thank you for purchasing and using TT-WE300 & TT-WE301 Electric Fryer. In order to making full use of functions of this product and minimize unnecessary loss and damage, please read the manual carefully and keep it for future reference.

WARNING!

ANY REFITTING AND WRONG INSTALLATION, ADJUSTMENT AND MAINTENANCE CAN LEAD TO PROPERTY LOSS AND CASUALTY.

PLEASE CONTACT THE SUPPLIER IF YOU NEED TO ADJUST OR MAINTAIN IT AND ALL THESE SHOULD BE DONE BY AUTHORIZED PROFESSIONALS.

WARNING!

DO NOT PUT FLAMMABLE LIQUID, GAS OR OTHER OBJECT AROUND THE PRODUCT FOR YOUR SAFETY SAKE.

WARNING!

THE SHEEL OF THIS MACHINE MUST BE GROUNDED FOR SAFETY SAKE. IF THE OIL LEVEL IS BELOW THE MINIMUM INDICATED LEVEL WILL CAUSE A FIRE.

THANK YOU FOR YOUR COOPERATION!

The design of this product is new and function is stable. It has features of beautiful appearance, reasonable structure, easy operation, constant temperature control, fast heating and saving oil and energy. It can cook, fry and warm food. It is an ideal assistant and first choice for cooking.

A. STRUCTURE, FUNCTIONS AND FEATURES

1. There are two kinds of EF-12L & EF-12L-2 Electric Fryer. One is 1-tank fryer; another is 2-tank fryer. 2-tank fryer can fry two kinds of different taste food in case of mixing the smell.
2. There is temperature controller in it and it can set temperature for frying. Power indicator and heating indicator can show the heating situation.
3. When temperature of oil is over the limited temperature, the protecting device of heat breaker can cut off power automatically. It can avoid being over temperature (reset the device by hand).
4. When lifting the electric box, the micro-switch works at once. It cut off power to make sure personal safety and in case of electric heating tube being dry burned.
5. The handle of frying basket can be folded and dismantled. It has a stainless steel moving oil tank with calibration mark of oil level. It is easy to be operated,

cleaned, transported and stored.

6. Electric heating tube has protecting board and it can be easy to draw out of bottom box with the electric box and separate from oil pot. Then it is easy to clean electric heating tube and oil pot.

B. BASIC PARAMETER

NAME	MODEL	VOLTAGE	POWER	DIMENSION	NUM OF OIL TANK	NUM OF FRYING BASKET
1-TANK FRYER	EF-12L	220~240V	3250W	290×550×410	1	1
2-TANK FRYER	EF-12L-2	220~240V	3250W×2	580×550×410	2	2

C. CIRCUIT DIAGRAM

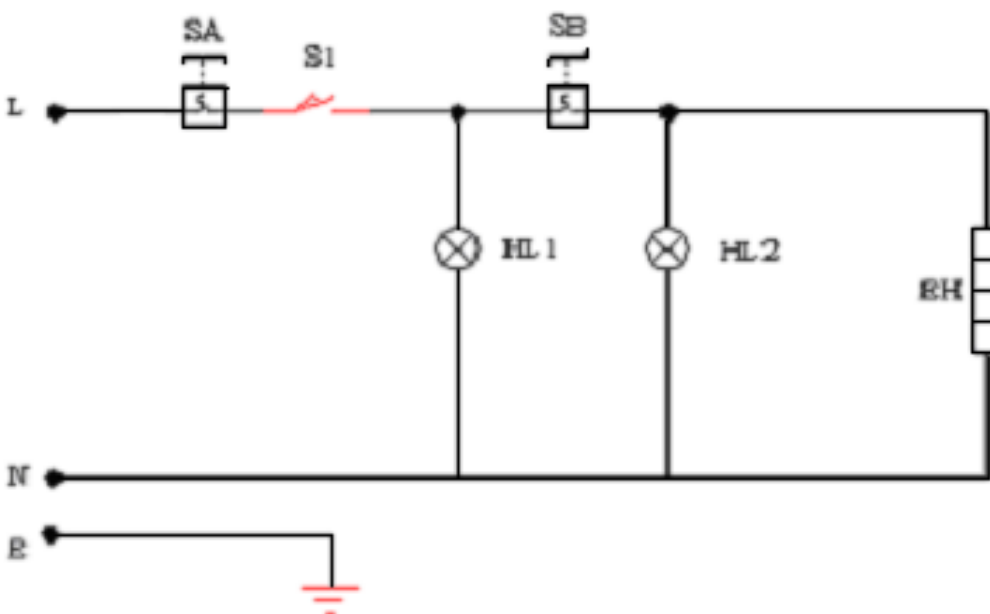

S1 — MICRO-SWITCH
 TEMPERATURE CONTROLLER
 HL1 — POWER INDICATOR
 E — EARTH OF CASE

SA — HEAT BREAKER
 SB —
 EH — ELECTRIC HEATING TUBE
 HL2 — HEATING INDICATOR

NOTICE: THE CIRCUIT PRINCIPLE OF EF-12L & EF-12L-2 1-TANK/2-TANK FRYER IS DIFFERENT.

D. INSTRUCTION

1. Check if the installation of power supply is normal, and make sure the supplied

- voltage is coordinated with the using voltage.
2. There is oil level mark in the internal oil pot, when using the quantity of oil in oil pot should be kept in certain level. “MAX” shows the most volume of oil, “MIN” shows the less volume of oil. When using user can adjust the volume of oil according to user’s need.
 3. 1) Plug the machine and get through power supply, green indicator is on. At that time current has been supplied to the machine.
2) Rotate the temperature controller clock—wise, put the needed temperature degree to the red point. At that time, the yellow indicator is on and green indicator is off. It shows that electric heating tube stops working and temperature of oil in pot is rising.
 4. 1) When temperature of oil rises to the setting temperature, temperature controller can cut off power automatically. At the same time, yellow indicator is off and green indicator is on.
2) When temperature of oil lowers, temperature controller can get through power automatically. Yellow indicator is on and green indicator is off, electric heating tube works again and temperature of oil rises.
3) It repeats again and again to make sure temperature of oil is constant in the setting temperature.
 5. The cover of pot is designed for keeping the pot be cleaning and warming. When putting in on the cover, please make sure there is not water on it in case of water drops into pot and oil splashes.
 6. 1) The enclosed frying basket for frying small food. There is hook and handle on the basket.
2) Soak the basket into oil when operating. When the frying is finished, lift the basket and hand it in the front notch of pot to filter oil. User can put big food into pot to fry.
 7. After working, please rotate the temperature controller counter-clockwise to the limit position and cut off power for safety sake.
 8. 1) Please pour the old oil out of pot when temperature of oil lowers to normal.
2) First, cut off power, then put a oil tray under the oil drain and open the drain valve to pour oil into the oil tray.
 9. In order to make sure the stove is safe and durable. User should clean dreg of oil pot and filth of electric heating tube in order to keep the oil pot and electric heating tube is clean.
 10. The partition board of oil pot is designed for protecting electric heating tube. Put the partition board into the oil pot when frying food.
 11. 1) There is temperature in electric box. The moving temperature is 230°C; reset temperature is less 170°C.
2) There is “reset button for over heating” out of the shell. When temperature is over, the protecting button works. Press the reset button to restart. If heat cut-out works again and again, please ask professional people to check and repair the fryer.

E. NOTES FOR INSTALLATION

1. The using voltage for this equipment must be coordinated with the supplied voltage.
2. User should install a suitable power switch and breaker switch near the fryer.
3. At the back of the equipment is the earth bolt. Please connect the earth wire in compliance with the safety regulations reliably with copper cable of no less than 1.5 mm².
4. Before using, check whether every connection is formed, voltage is normal and ground connection is safe.
5. The temperature around the fryer should not be over 300°C in order to prevent from hot oil splashing and cause fire.
6. The installation of this stove must be done by professionals.

A. Notice

- This equipment must be operated by trained cook or professionals.
- Do not refit it! The refitment of this product will cause serious accident.
- Do not clean the product with a water jet or soak electric box into water to clean. Water can conduct electricity so the product may cause electric-shock accident by electricity leakage.
- High temperature will cause scald. When fire-facing oven is in use and before or after being used, do not touch directly body of trunk and chamber of top truck because of high temperature.
- Do not use another power supply with different voltage.
Do not use main switch that is not coordinated with safety regulation.
- When thunder and lightning is closing, user should shut off main switch to avoid appliance being damaged by lightning strike.
- Do not use hard and sharp object to destroy the surface of oven body and the surface of oil pot.
- Hand should be dry to install the fryer and the plug and switch should be dry to connect.
- The installation and maintenance of electric circuit by professionals.
- If power cord is damaged, for preventing from danger, user should ask manufacturer or maintenance department or specific professionals to change it.

F. Troubleshooting

Troubles	Causes	Solution
1. Plug the machine and get through power supply, power indicator is not on and heat.	<ol style="list-style-type: none"> 1. Plug is not inserted well. 2. Micro-switch contacts not well. 	<ol style="list-style-type: none"> 1. Remove the plug. 2. Adjust the limit distance of micro-switch

2. Heating indicator is not on and temperature is not raised.	1. Connection of electric heating tube is loose. 2. Heating tube is burned.	3. Firm two sides of electric heating tube and screw. 4. Change electric heating tube.
3. Power indicator is on but the setting temperature is not raised.	1. Temperature controller is burned.	1. Change temperature controller.
4. Temperature control is normal but indicator is not on.	1. Indicator is burned.	1. Change indicator.
5. After circuit heating, electric heating tube is not heated.	1. Temperature limiter works.	1. Reset “over heating protecting button” by hand.
6. Temperature control can not be controlled.	1. Temperature limiter is out of control.	1. Change temperature limiter.

Aforementioned troubles are just for reference. If any fault occurs, please cease using, return it to professional technicians for check and repair.

G. Transportation and storage

During transportation, the machine should be careful handled and prevent from shaking. The packaged machine should not be stored in the open air. It should be put in a ventilated warehouse without corrosive gas. It should not be put upside down. If it needs to be stored in open air temporary, measurement against raining in needed.

H. Cleaning and maintenance

1. Cut off the power supply before cleaning in case of accident.
2. Do not use wet towel with non-corrosive cleanser to clean the fryer. Direct wash by water is not permitted in case of any damage of the functions.
3. If do not use it at any time, please turn off temperature controller and main switch.
4. Please store the equipment in a ventilated storehouse without corrosive gas after cleaning when ceasing its work for a long time.

I. Daily check

Notice the situation of the machine before or after using everyday.

Before using	Whether the machine is tilted?
	Whether the power cord is old, broken or damaged?
	Whether the control panel is damaged?
After using	Whether there is strange smell?
	Whether the upper and lower module plate cannot be heated at the same time?

Is there any strange voice or is the machine out of control while the machine is lifting?

WARNING!

-
- Must check the machine everyday.
Usually check the product that can avoid serious accident happens.
The temperature around the machine should not over 300°C.
 - Stop using if user feels that there are some problems in the circuit or machine.
Ask the special technicians to check and maintain the machine as soon as possible.
-