

QUALITY · INTEGRITY · INNOVATIONS · SAFETY



✉ sales@twothousand.com

🌐 www.twothousand.com

☎ +862038768241

📍 105, 18 West St, Huagang, Tianhe, Guangzhou, China





## ABOUT **TWOTHOUSAND**

Twothousand Machinery is a manufacturing 2.0 company that specializes in the development and manufacturing of intelligent food equipment for the bakery industry. The company was founded in 2000 by a renowned Chinese commercial food mixer manufacturer with the purpose of elevating and expanding product lines through the integration of digital operations and IOT technologies. Our extensive range of products includes food mixers, dough mixers, dough sheeters, dough presses, bread slicers, and more.

We are committed to providing the highest quality food equipment and unparalleled service to our esteemed clients and the industry. Our team of experienced professionals is dedicated to innovative strategies and creative solutions to ensure that we remain at the forefront of the industry.

### OUR BRANDS



## OUR PRINCIPLES

# 01

### QUALITY

*Highest demands on quality control. With the help of the self-developed quality inspection robot, the inspection control is much more accurate and reliable.*

# 02

### INTEGRITY

*Consistent and uncompromising integrity makes our business much more prosperous. The integrity is the foundation of our company's development.*

# 03

### INNOVATIONS

*Big investment on the intelligent products innovation development base on the markets demand. To manufacture the intelligent products are our vision.*

# 04

### SAFETY

*Safety responsibility is important to the products' operation and production. We produce and design the products under the safety standards strictly.*



## OUR APPROVALS



*Applying ETL safety certificates to the products, to guarantee the quality products and safety operation, which can improve product competitiveness.*



*The food equipment with ETL Sanitation certification can greatly improve consumers' desire to purchase, the food standard safety should come to the first.*



*Our stand mixers are NSF listed, the NSF standard materials in food contact components to help protect water, food, consumer products and the environment.*



*ME Technology designs and manufactures the products under the CE standards to guarantee the facility safety and food sanitation for the European customers.*

## CATALOG CONTENTS

<b>STAND MIXER</b>	PAGE 10
<b>PLANETARY MIXER</b>	PAGE 12
<b>DOUGH MIXER</b>	PAGE 16
<b>DOUGH PRESS</b>	PAGE 20
<b>EMPANADA MACHINE</b>	PAGE 26
<b>BREAD SLICER</b>	PAGE 27
<b>DOUGH SHEETER</b>	PAGE 28
<b>BLAST CHILLER</b>	PAGE 30



# TABLE TOP STAND MIXER



**TWOTHOUSAND** specializes in manufacturing intelligent commercial food mixers and related products to the food service industry. Designed with 5 variable speeds, our commercial table top mixers are an ideal choice for whipping potatoes, making cakes, or aerating egg whites.

**ETL Listed** commercial stand mixers meet the standard of UL and NSF, for use in the United States and Canada. Ensure high safety and sanitation standards.

### THREE MIXING ATTACHMENTS ARE EQUIPPED



DOUGH HOOK

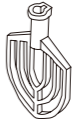

FLAT BEATER



WIRE WHIP

*\* MEAT MINCER, PASTA KITS AND GUARD ARE OPTIONAL*

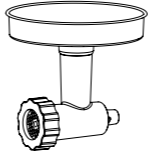

MEAT MINCER

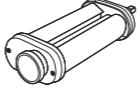

PASTA ROLLER

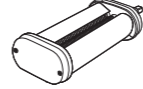

SPAGHETTI CUTTER

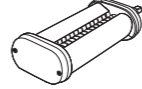

FETTUCCINE CUTTER



PROTECTION GUARD

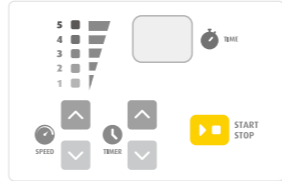

MODEL	B7CT	B12P
FEATURES	DIGITAL CONTROL	DIGITAL CONTROL WITH PROGRAM PRESETS
CAPACITY / MAX FLOUR	7 LITER / 800G FLOUR	12 LITER / 2500G FLOUR
VOLTAGE	220V / 110V	220V / 110V
POWER	600 WATT	650 WATT
SIZE	460X340X520 MM	422X513X612 MM
WEIGHT	20 KG	34 KG



# PLANETARY MIXER

The commercial planetary mixers are suitable for restaurants, bakeries, café to process the food mixing job. With the planetary mixer from **TWOTHOUSAND**, you could easily handle kitchen food preparation tasks, whipping potatoes, making cake batter, and a variety of other food items.

**Three Attachments** are come with the planetary mixers, a wire whip for beating eggs, soft creams, a flat beater as a fundamental tool for mixing any food items, and a dough hook for dough mixing.

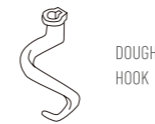

DOUGH HOOK



FLAT BEATER



WIRE WHIP

## GEAR DRIVEN HEAD AND EASY CONTROL PANEL

Equipped with a **gear driven** top head for this unit, it will provide enough power to mixing food. All the simple but vital buttons and switches are on the power top head for easy machine control.

## STRONG BOWL LOCATING LOCK

This unit features a strong bowl locating lock, which will keep the bowl in the right place and will not slip off during the machine working. The strong fasten structure design ensures the stability of the working state.



MODEL	TT-MA10	TT-MA20	TT-MA30	TT-MA40
CAPACITY	10 LITER	20 LITER	30 LITER	40 LITER
MAX FLOUR	2.5 KG	5.0 KG	7.0 KG	9.0 KG
SPEED	148 / 244 / 480 RPM	130 / 234 / 418 RPM	165 / 270 / 560 RPM	165 / 270 / 560 RPM
POWER	600 WATT	1100 WATT	2300 WATT	2380 WATT
SIZE	470X390X720 MM	500X450X900 MM	630X530X1180 MM	660X560X1210 MM
WEIGHT	58 KG	86 KG	140 KG	150 KG



Intertek



Intertek





# PLANETARY MIXER



**Belt-Driven** planetary mixers are known for their smooth and quiet operation, with the belt absorbing shock and vibration, resulting in less noise and a smoother mixing process. These mixers also generate less heat than gear-driven ones, which can be beneficial when working with temperature-sensitive ingredients.

Belt-driven mixers are easier to maintain due to having fewer moving parts, making them a more affordable option in the long run. The belts can be easily replaced when necessary, and there is less risk of internal damage due to wear and tear.

**Three Attachments** are come with the planetary mixers, a wire whip for beating eggs, soft creams, a flat beater as a fundamental tool for mixing any food items, and a dough hook for dough mixing.



### FEATURES

- > Belt Driven
- > 3 Attachments
- > Easy to Use
- > Commercial Use
- > With Safety Guard
- > **Timer for 20, 30 and 40 Liter**

MODEL	B10M	B20M	B30M	B40M
CAPACITY	10 LITER	20 LITER	30 LITER	40 LITER
MAX FLOUR	2.5 KG	5.0 KG	7.0 KG	9.0 KG
SPEED	114 / 234 / 460 RPM	140 / 276 / 540 RPM	134 / 234 / 460 RPM	134 / 234 / 460 RPM
VOLTAGE	110V / 220V	220V / 380V	220V / 380V	220V / 380V
POWER	600 WATT	900 WATT	1300 WATT	1300 WATT
SIZE	480X420X820 MM	570X480X950 MM	660X665X1200 MM	680X645X1250 MM
WEIGHT	58 KG	78 KG	128 KG	138 KG



# DOUGH MIXER

With a humanized and fashionable design, this high performance, intelligent flour dough mixer is perfect for the pizzeria, pastry shop, bakery. It is a vital tool for bakeries and those restaurants with a high demand for popular dough products.

## DIGITAL CONTROL PANEL

We have various capacities of this heavy-duty flour dough mixer machine for your options. This unit is designed with digital timer and 10 variable speeds for dough kneading, making your work more flexible.

## STABLE OPERATION

**Gear and belt** drive design ensures the stability of the dough mixing job, make the process finished quietly. Plus, a flat-top head design for this intelligent programmable spiral mixer, allows you have a working bench for your convenient kitchen job.

## HEAVY DUTY

This powerful dough mixer can handle heavy loads each time, helping you expedite dough production and increase your business's productivity. It offers superb quality at a moderate price.

HX20  
HX30  
HX40



HX20 / HX30 / HX40

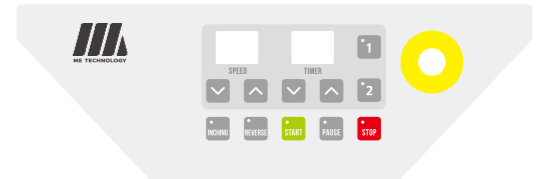

HX50 / HX60



HX50  
HX60



MODEL	HX20	HX30	HX40	HX50	HX60
CAPACITY	23 LITER	34 LITER	45 LITER	55 LITER	66 LITER
MAX FLOUR	8.0 KG	12.5 KG	20.0 KG	25.0 KG	30.0 KG
SPEED	130 - 320 RPM	130 - 320 RPM	130 - 320 RPM	130 - 320 RPM	130 - 320 RPM
POWER	1300 WATT	1800 WATT	2600 WATT	3300 WATT	3300 WATT
SIZE	730X500X770 MM	850X520X860 MM	850X520X920 MM	1100X680X1150 MM	1150X720X1200 MM
WEIGHT	90 KG	120 KG	145 KG	170 KG	180 KG



Intertek



Intertek



# COUNTERTOP DOUGH MIXER

The counter top HX10 mixer can handle large amounts of dough or batter, with coordinated spiral and bowl rotation for optimal blending. The digital control panel offers easy speed adjustment and a timer function for precise results.

The counter-top dough mixer **HX10TM** with a lifting top feature is designed to make the process of extracting dough and cleaning the machine as effortless as possible. The innovative lift-up mechanism allows you to easily access the dough once it's finished mixing, without having to awkwardly reach deep into the machine. This not only makes the task of removing the dough more convenient but also helps to prevent any potential injuries that could arise from straining or twisting your arms.



Intertek



Intertek



### FEATURES

- > Counter top Dough Mixer
- > Digital Control
- > Safe to Use
- > Durable

- > Commercial Use
- > **Removal Bowl (HX10TM)**
- > **Tilting Head**
- > **Dough Temperature Display**



MODEL	HX10	HX10TM
BOWL CAPACITY	10 LITER	10 LITER
MAX FLOUR	3.5 KG	3.5 KG
VOLTAGE	220V / 110V	220V / 110V
POWER	750 WATT	750 WATT
SIZE	550X315X435 MM	550X315X435 MM
WEIGHT	29 KG	29 KG
SPIRAL SPEED	109 - 243 RPM	109 - 243 RPM
BOWL SPEED	11 - 24 RPM	11 - 24 RPM



# DOUGH PRESS



Commercial dough press machine from **TWOTHOUSAND** is ideal for the Pizzeria, Cafes, School to meet the medium to high production volumes. With this dough press machine, we could make many kinds of dough products like Pizza Crust, Chapati, Pita Bread, Parathas, Lavash, and Mexican Tortilla that kind of food.

### DIGITAL CONTROL AND ADJUST THICKNESS

Features a digital control panel, you could control the temperature and time for the dough pressing process and adjust the thickness for the pizza dough as desired. The dough ball and the thickness setting will determine the size of the pizza crust.

### PRESET PROGRAMS

The dough press machine features the procedure recording function, that is to record a pizza press process, next time just selected procedure, the machine will run the same process automatically. It really an affordable way to improve production time.

### FEATURES

- > Reliable
- > Heavy Duty
- > Accurate and Even Dough Products
- > Almost 200-400 / Hour
- > Simple and Easy Control
- > Thickness Adjustable
- > Modern Design
- > Stable Body



MODEL	ME-P18M
PLATE SIZE	18 INCH
TEMPERATURE	0 - 200°F (93°C) (UPPER PLATE)
VOLTAGE	110V / 220V
POWER	1200 WATT
SIZE	WIDTH 470 MM X DEPTH 765 MM X HEIGHT 470 MM
WEIGHT	99 KG



# CLAMSHELL DOUGH PRESS

Easy operation manual type pizza dough press machine flattens the dough ball into uniform crusts in a little time. With this unit, you could easily press a variety of dough types for making the Mexican Tortilla, Pizza Crust, Pita Bread, Chapati, Parathas, and Lavash that kind food.



### THICKNESS ADJUSTABLE

Besides, it features a full range of thickness adjustments, which means you could decide how thick the dough you want to press by adjusting the pressing thickness and the dough ball size.

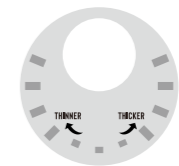

### TEMPERATURE ADJUSTABLE

The upper platen's embedded heating elements ensure consistent and even heating. You can adjust the temperature for different types of dough. And the heating feature can be turned off as well.

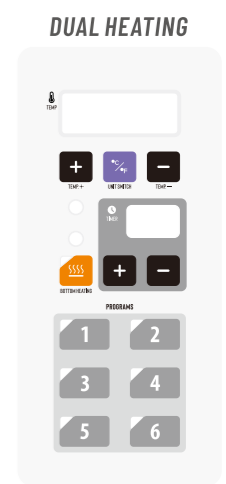

### FEATURES

- > Clamshell Design
- > Heated Upper Platen
- > Thickness Adjustable
- > Durable
- > Up to 18 Inches Dia.
- > Timer and Temp Control



MODEL	ME-P18E-U	ME-P18E-UB	ME-P18E-N	ME-P18ES
PLATE SIZE	18 INCH	18 INCH	18 INCH	16 X 20 INCH
PLATE SHAPE	ROUND	ROUND	ROUND	RECTANGLE
HEATED METHOD	UPPER HEATING	UPPER AND BOTTOM HEATING	NO HEATING	UPPER AND BOTTOM HEATING
VOLTAGE	110V / 220V	220V	N/A	220V
POWER	1200 WATT	3300 WATT	N/A	3600 WATT
SIZE	470X765X470 MM (CLOSE SIZE)	470X765X470 MM (CLOSE SIZE)	470X765X470 MM (CLOSE SIZE)	470X816X470 MM (CLOSE SIZE)
WEIGHT	49 KG	51 KG	47 KG	57 KG

# SWING AWAY DOUGH PRESS

The swing type dough press is perfect for creating pizza crusts, as it produces a similar texture to hand-stretched dough for 18" crusts. It's incredibly user-friendly, making it safe and suitable for unskilled labor. With just a single press, it can significantly speed up the production process and result in flawless dough.



## FEATURES

- > Swing Away Design
- > **Upper and Bottom Heating**
- > **Thickness Adjustable**
- > Durable
- > **Up to 18 Inches Dia.**
- > **Timer and Temp Control**

MODEL	ME-SP18E-UM
PLATE SIZE	18 INCH
TEMPERATURE	0 - 200°F (93°C)
VOLTAGE	240V
POWER	1650 WATT X 2
SIZE	610X476X412 MM
WEIGHT	99 KG
MAX. SWING ANGLE	90°C
ADJUSTABLE THICKNESS	1 - 30 MM

# TORTILLA WARMER



Our tortilla warmer is a great fit for Mexican restaurants. It is designed to keep tortillas warm for 20 seconds on each side, resulting in a hot but not overly heated burrito wrap.

With the ability to heat up to eight tortillas every 40 seconds, the warmer can easily handle sudden demands from customers.

The warmer utilizes a single heater to provide consistent platen heat, resulting in uniformly cooked tortillas. Made of stainless steel, the warmer is durable and can withstand scraping from spatulas.



## FEATURES

- > Temperature Control
- > **Uncoated Aluminum Plate**
- > Even Heating
- > Durable Construction
- > Adjustable Feet
- > Stainless Steel Body



MODEL	ME-W16E
PLATE SIZE	406X508 MM (16X20 INCH)
TEMPERATURE	MAX 200°C (392°F)
POWER	1800 WATTS
VOLTAGE	220V 60HZ
SIZE	550X445X125 MM
WEIGHT	23 KG



# EMPANADA MACHINE



The DEM-10 Manual Pastries Meat Pie Empanadas Maker Turnover Machine is a automatic and versatile machine capable of producing 500 to 600 Empanadas or Samosas per hour with a single operation, without the need for prior experience or specialized knowledge.

### FEATURES

- > Fast and Efficient Production
- > Easy and Simple Operation
- > Perfect Seal Ensured
- > Full Stainless Steel Body
- > Various Die Casting



### VARIOUS DIES

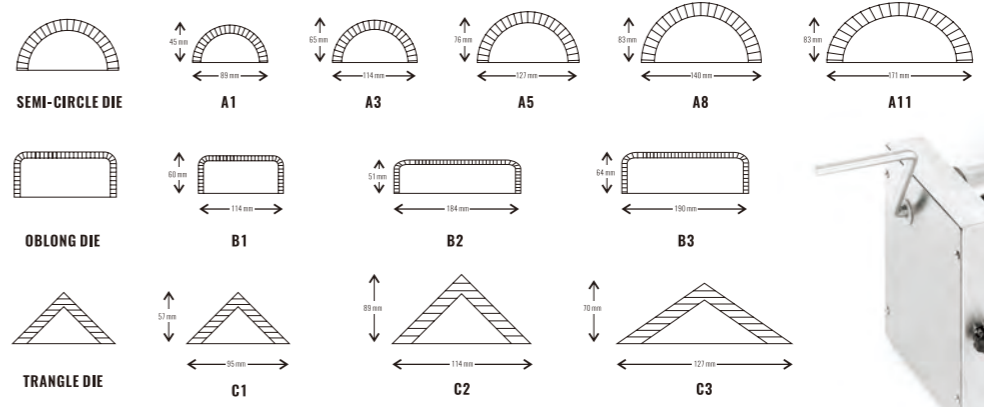

MODEL	DEM-10
MACHINE SIZE	520X250X270 MM
NET WEIGHT	9.5 KG
PRODUCTION	600 PCS / HOUR
MATERIAL	STAINLESS STEEL 304 / 1.5 MM THICKNESS

# BREAD SLICER

Slice the bread into equally sized slices with several simple steps with the ME Technology counter-top bread slicer. The unit is designed with fixed slicing thickness, allow to cut a loaf of bread into the same thicknesses of slice quickly and precisely. Smaller space occupation, easy to replace the slicing blade, low noise, and stable performance.

## ETL SAFETY AND ETL SANITATION LISTED

ETL Listed bread slicer meet the standard of UL, CSA and NSF, Ensure high safety and sanitation standards.



Intertek



Intertek



### OPTIONAL FEATURES

**Bread Pusher** is optional to install, which provides enough distance from the workers' operation hands to the machine slicing blade, reducing the potential injury.

**Bread Bagger** is optional, easily wrap and pack the bread with the bagger on the top safety board.

**Protective Guard** is optional that to protect the operator's hands, to ensure a safe bread slicing operation.

**Breadcrumbs Tray** is optional, installed under the machine, allow to easily collecting and cleaning the bread crumbs.



## DURABLE AND STABLE

The bread slicer is made of stainless steel, equipped with an imported blade and motor, which ensures the long life. Undoubtedly, it will be the best tool to promote business and make more profit.

MODEL	TT-D7BE
SLICE THICKNESS	12 MM / 16 MM / 19 MM / 25 MM (NOT ADJUSTABLE)
MAX BREAD	475 MM X 150 MM (WIDTH X HEIGHT)
VOLTAGE	110V / 220V
POWER	200 WATT
SIZE	675X630X740 MM
WEIGHT	80 KG

# DOUGH SHEETER

The reversible dough sheeter from ME Technology is ideal for bakeries and pizzerias to sheet and stretches the dough, finish the dough preparation job. Having the right tools makes a huge difference. The reversible dough sheeters machine makes it possible to achieve the consistent thickness of dough and allows to work quickly.

## ETL SAFETY AND ETL SANITATION LISTED

ETL Listed dough sheeter meet the standard of UL, CSA and NSF, Ensure high safety and sanitation standards.



Intertek



Intertek



## HIGH EFFICIENCY DOUGH SHEETER

With this reversible dough sheeter, you can easily roll dough to the right thickness for the intended purpose. The dough sheeter could quickly roll out several pounds of dough per minute. No need to worry about running out of the prepared dough, it is easy to meet the high demands of



MODEL	TT-D18A	TT-D18B	TT-D19A-1	TT-D19B-1
CONVEYOR BELT SIZE	430X1700 MM	500X2000 MM	500X2000 MM	630X2400 MM
WORKING WIDTH / HEIGHT	1770 MM / 620 MM	2080 MM / 620 MM	2550 MM / 1180 MM	2950 MM / 1180 MM
RESTING WIDTH / HEIGHT	750 MM / 710 MM	750 MM / 840 MM	680 MM / 1600 MM	780 MM / 1780 MM
ROLLER SIZE	DIA. 88X450 MM	DIA. 88X520 MM	DIA. 90X520 MM	DIA. 93X630 MM
VOLTAGE / POWER	110V / 220V / 560 WATT	110V / 220V / 560 WATT	110V / 220V / 560 WATT	110V / 220V / 750 WATT
SIZE	820X1770X620 MM	880X2080X620 MM	880X2550X1180 MM	1100X2950X1180 MM
WEIGHT	117 KG	125 KG	190 KG	225 KG



# BLAST CHILLER FREEZER



Blast chiller freezers are top-of-the-line equipment that rapidly lowers the temperature of freshly prepared food, ensuring its quality and freshness during storage. The speed at which this process occurs is crucial in maintaining the quality of the dish and controlling the growth of bacteria. The undeniable benefits of using blast chillers in commercial kitchens make them an indispensable tool for any professional chef or catering service.

### FEATURES

- > Italian Dixell Thermostat
- > Stainless Steel 304 Body
- > EBM German Blower
- > Ventilated
- > **Embraco / Tecumseh** Compressor
- > Low Noise

### FAST REFRIGERATION SPEED

This blast freezer can freeze products within 30 minutes with a temperature range of +30°C to -30°C, significantly reducing the risk of bacteria growth due to its efficient cooling speed.

### 75 MM THICK THERMAL INSULATION

The foaming body of this blast freezer is smooth, and the foaming has 75 mm and wrapped with 1.1 mm thick stainless steel 304.



MODEL	GC-BC3	GC-BC5	GC-BC10	GC-BC15
TRAY QTY	3 TRAYS	5 TRAYS	10 TRAYS	15 TRAYS
CHAMBER CAPACITY	40 LITER	160 LITER	310 LITER	345 LITER
CHAMBER SIZE	340X365X320 MM	650X400X425 MM	650X755X425 MM	650X1085X425 MM
SIZE	725X665X515 MM	790X730X913 MM	790X730X1398 MM	790X730X1807 MM
WEIGHT	58 KG	93 KG	128 KG	185 KG
POWER	500 WATTS	870 WATTS	1100 WATTS	1950 WATTS
COMPRESSOR	EMBRACO / SECOP	EMBRACO / SECOP	EMBRACO / SECOP	TECUMSEH



SERVE SINCE 2000

**TWOTHOUSAND**

INTELLIGENT COMMERCIAL KITCHEN EQUIPMENT MANUFACTURER