

QUALITY · INTEGRITY · INNOVATIONS · SAFETY



✉ sales@twothousand.com  
🌐 www.twothousand.com  
☎ +862038768241  
📍 105, 18 West St, Huagang, Tianhe, Guangzhou, China





## ABOUT **TWOTHOUSAND**

Founded in 2000, TWOTHOUSAND® is a leading bakery equipment manufacturer, committed to industry innovation through affordability and digital advancements. Our product range: includes planetary mixers, dough mixers, dough presses, dough sheeters, bread slicers, and more.

OUR  
**CUSTOMERS**



OUR  
**ADVANTAGES**



**23 - YEARS**  
Professional  
Experience



**1000 +**  
Satisfied  
Customers



**120 +**  
Countries  
Served

## OUR APPROVALS



## CATALOG CONTENTS

<i>STAND MIXER</i>	<i>PAGE 10</i>
<i>PLANETARY MIXER</i>	<i>PAGE 12</i>
<i>DOUGH MIXER</i>	<i>PAGE 20</i>
<i>DOUGH PRESS</i>	<i>PAGE 24</i>
<i>ICE CREAM BLENDER</i>	<i>PAGE 28</i>
<i>EMPANADA MACHINE</i>	<i>PAGE 30</i>
<i>BREAD SLICER</i>	<i>PAGE 31</i>
<i>DOUGH SHEETER</i>	<i>PAGE 32</i>
<i>BLAST CHILLER</i>	<i>PAGE 34</i>



# TABLE TOP STAND MIXER

- ✓ Digital Controls and Timer
- ✓ Variable Speeds
- ✓ ETL and NSF Certified
- ✓ Stainless Steel Accessories



## THREE MIXING ATTACHMENTS ARE EQUIPPED

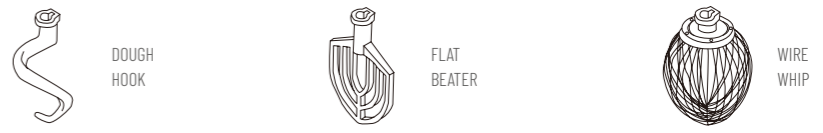

## \* MEAT MINCER, PASTA KITS AND GUARD ARE OPTIONAL

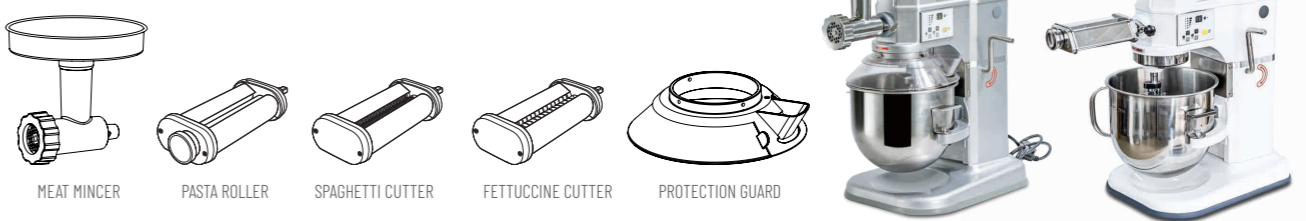

7 LITER

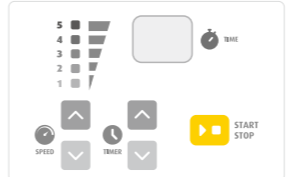

12 LITER



MODEL	B7D	B12P
FEATURES	DIGITAL CONTROL	DIGITAL CONTROL WITH PROGRAM PRESETS
CAPACITY / MAX FLOUR	7 LITER / 800G FLOUR	12 LITER / 2500G FLOUR
VOLTAGE	220V / 110V	220V / 110V
POWER	600 WATT	650 WATT
SIZE	460X340X520 MM	422X513X612 MM
WEIGHT	20 KG	34 KG



SCAN QR CODE FOR VIDEO OF THIS STAND MIXER



# PLANETARY MIXER

- ✓ Gear Driven
- ✓ Ideal for Heavy Duty Mixing Tasks
- ✓ Easy to Use
- ✓ Stainless Steel Accessories

**Three Attachments** are come with the planetary mixers, a wire whip for beating eggs, soft creams, a flat beater as a fundamental tool for mixing any food items, and a dough hook for dough mixing.



DOUGH HOOK



FLAT BEATER



WIRE WHIP

## GEAR DRIVEN HEAD AND EASY CONTROL PANEL

Equipped with a **gear driven** top head for this unit, it will provide enough power to mixing food. All the simple but vital buttons and switches are on the power top head for easy machine control.

## STRONG BOWL LOCATING LOCK

This unit features a strong bowl locating lock, which will keep the bowl in the right place and will not slip off during the machine working. The strong fasten structure design ensures the stability of the working state.



MODEL	TT-MA10A	TT-MA20A	TT-MA30A	TT-MA40A
CAPACITY	10 LITER	20 LITER	30 LITER	40 LITER
MAX FLOUR	2.5 KG	5.0 KG	7.0 KG	9.0 KG
SPEED	148 / 244 / 480 RPM	197 / 317 / 462 RPM	165 / 270 / 560 RPM	165 / 270 / 560 RPM
POWER	600 WATT	1100 WATT	2300 WATT	2380 WATT
SIZE	470X390X720 MM	500X450X900 MM	630X530X1180 MM	660X560X1210 MM
WEIGHT	58 KG	86 KG	140 KG	150 KG

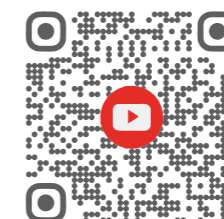

SCAN QR CODE FOR VIDEO OF THIS PLANETARY MIXER



Intertek



Intertek





# DIGITAL PLANETARY MIXER

- ✓ Gear Driven
- ✓ Ideal for Heavy Duty Mixing Tasks
- ✓ Easy to Use
- ✓ Stainless Steel Accessories

**Three Attachments** are come with the planetary mixers, a wire whip for beating eggs, soft creams, a flat beater as a fundamental tool for mixing any food items, and a dough hook for dough mixing.



DOUGH HOOK



FLAT BEATER



WIRE WHIP

## GEAR DRIVEN HEAD

Equipped with a **gear driven** top head for this unit, it will provide enough power to mixing food.

## DIGITAL CONTROL PANEL

All the simple but vital buttons and switches are on the power top head for easy digital control.



## STRONG BOWL LOCATING LOCK

This unit features a strong bowl locating lock, which will keep the bowl in the right place and will not slip off during the machine working. The strong fasten structure design ensures the stability of the working state.



Intertek



Intertek

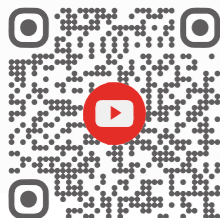

SCAN QR CODE FOR VIDEO OF THIS PLANETARY MIXER

MODEL	TT-MA10	TT-MA20	TT-MA30	TT-MA40
CAPACITY	10 LITER	20 LITER	30 LITER	40 LITER
MAX FLOUR	2.5 KG	5.0 KG	7.0 KG	9.0 KG
SPEED	148 / 244 / 480 RPM	197 / 317 / 462 RPM	165 / 270 / 560 RPM	165 / 270 / 560 RPM
POWER	600 WATT	1100 WATT	2300 WATT	2380 WATT
SIZE	470X390X720 MM	500X450X900 MM	630X530X1180 MM	660X560X1210 MM
WEIGHT	58 KG	86 KG	140 KG	150 KG



# FREQUENCY DRIVE PLANETARY MIXER

The BX Frequency Drive Planetary Mixer offers variable speeds, speed memory, and timing functions for commercial kitchens. It handles current fluctuations safely, stays cool under 50 degrees, and operates quietly, ensuring efficiency and reliability for all your mixing needs. Elevate your culinary creations with the BX mixer!

- ✓ Belt Driven
- ✓ Frequency Drive Motor
- ✓ Low Noise and More Stable
- ✓ Stainless Steel Accessories

### Three Attachments

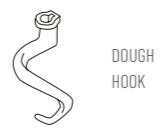

DOUGH HOOK

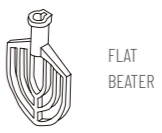

FLAT BEATER



WIRE WHIP

### VARIABLE SPEEDS

Offers a wide range of mixing speeds for versatility.

### SPEED MEMORY & TIMING FUNCTION

Enhances usability for commercial kitchens.

### ROBUST POWER SYSTEM

Tolerates current fluctuations to reduce motor damage risk.

### SEAMLESS SPEED ADJUSTMENT

Change speeds without stopping the mixer.

### LOW HEATING

Stays below 50 degrees after 30 minutes of use.

### LOW NOISE PERFORMANCE

Operates quietly for a comfortable kitchen.



BX10  
BX20



BX30  
BX40



BX60  
BX80

MODEL	BX10	BX20	BX30	BX40	BX60	BX80
CAPACITY	10 LITER	20 LITER	30 LITER	40 LITER	60 LITER	80 LITER
MAX FLOUR	2.5 KG	5 KG	7 KG	9 KG	25 KG	30 KG
POWER	750 WATT	1000 WATT	1500 WATT	1500 WATT	2500 WATT	2500 WATT
SIZE	446X512X734 MM	487X618X853 MM	662X752X1140 MM	662X754X1190 MM	816X940X1398 MM	840X950X1450 MM
WEIGHT	41.5 KG	63 KG	123 KG	128 KG	338 KG	348 KG



# PLANETARY MIXER

**Belt-Driven** planetary mixers are known for their smooth and quiet operation, with the belt absorbing shock and vibration, resulting in less noise and a smoother mixing process. These mixers also generate less heat than gear-driven ones, which can be beneficial when working with temperature-sensitive ingredients.

- ✓ Belt Driven
- ✓ Less Noise and Smoother Mixing
- ✓ Easier Maintenance
- ✓ Easy Belt Replacement When Needed

**Three Attachments** are come with the planetary mixers, a wire whip for beating eggs, soft creams, a flat beater as a fundamental tool for mixing any food items, and a dough hook for dough mixing.



### FEATURES

- > Belt Driven
- > 3 Attachments
- > Easy to Use
- > Commercial Use
- > With Safety Guard
- > **Timer for 30 and 40 Liter**

MODEL	B10M	B20M	B30M	B40M
CAPACITY	10 LITER	20 LITER	30 LITER	40 LITER
MAX FLOUR	2.5 KG	5.0 KG	7.0 KG	9.0 KG
SPEED	114 / 234 / 460 RPM	140 / 276 / 540 RPM	134 / 234 / 460 RPM	134 / 234 / 460 RPM
VOLTAGE	110V / 220V	220V / 380V	220V / 380V	220V / 380V
POWER	600 WATT	900 WATT	1300 WATT	1300 WATT
SIZE	480X420X820 MM	570X480X950 MM	660X665X1200 MM	690X645X1250 MM
WEIGHT	58 KG	78 KG	128 KG	138 KG



# DOUGH MIXER

- ✓ High Performance
- ✓ Humanized and Fashionable Design

- ✓ Various Capacities Available
- ✓ Super Silent



Intertek



Intertek



## DIGITAL CONTROL PANEL

This unit is designed with digital timer and 10 variable speeds for dough kneading, making your work more flexible.

HX20 / HX30 / HX40

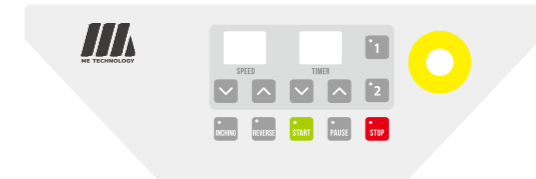

## STABLE OPERATION

**Gear and belt** drive design ensures the stability of the dough mixing job, making the process finished quietly.

HX50 / HX60



## HEAVY DUTY

This robust dough mixer is capable of effortlessly handling heavy loads, allowing you to expedite dough production and boost your business's productivity. It offers exceptional quality at a reasonable price point.

HX20  
HX30  
HX40



HX50  
HX60



MODEL	HX20	HX30	HX40	HX50	HX60
CAPACITY	23 LITER	34 LITER	45 LITER	55 LITER	66 LITER
MAX FLOUR	8.0 KG	12.5 KG	20.0 KG	25.0 KG	30.0 KG
SPEED	130 - 320 RPM	130 - 320 RPM	130 - 320 RPM	130 - 230 RPM	130 - 230 RPM
POWER	1300 WATT	1800 WATT	2600 WATT	3300 WATT	3300 WATT
SIZE	730X500X770 MM	850X520X860 MM	850X520X920 MM	1100X680X1150 MM	1150X720X1200 MM
WEIGHT	90 KG	120 KG	145 KG	170 KG	180 KG

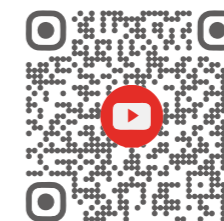

SCAN QR CODE FOR VIDEO OF THIS DOUGH MIXER

# COUNTERTOP DOUGH MIXER



**MODEL: HX10**

- ✓ High capacity for dough / batter
- ✓ Consistent spiral and bowl rotation
- ✓ Digital control panel
- ✓ Easy speed adjustment

**HX10TM MIXER WITH LIFTING TOP**

- ✓ Easy lifting design
- ✓ Real-time temperature display
- ✓ Precise timing



MODEL	HX10	HX10TM
BOWL CAPACITY	10 LITER	10 LITER
MAX FLOUR	3.5 KG	3.5 KG
VOLTAGE	220V / 110V	220V / 110V
POWER	750 WATT	750 WATT
SIZE	550X315X435 MM	550X315X435 MM
WEIGHT	29 KG	29 KG
SPIRAL SPEED	109 - 243 RPM	109 - 243 RPM
BOWL SPEED	11 - 24 RPM	11 - 24 RPM



SCAN QR CODE FOR VIDEO OF THIS COUNTER-TOP DOUGH MIXER



# DOUGH PRESS



- ✔ Digital control panel for precise adjustments
- ✔ Customized pizza crust thickness
- ✔ Procedure recording for easy replication
- ✔ Effortless saving and selection of procedures
- ✔ Time Saving and ensured consistency
- ✔ Boost efficiency with our versatile machine

Commercial dough press machine from **TWOTHOUSAND** is ideal for the Pizzeria, Cafes, School to meet the medium to high production volumes. With this dough press machine, we could make many kinds of dough products like Pizza Crust, Chapati, Pita Bread, Parathas, Lavash, and Mexican Tortilla that kind of food.

## FEATURES

- > Reliable
- > Heavy Duty
- > Accurate and Even Dough Products
- > Almost 200-400 / Hour
- > Simple and Easy Control
- > Thickness Adjustable



MODEL	ME-P18M
PLATE SIZE	18 INCH
TEMPERATURE	MAX. 200°F (93°C)
VOLTAGE	110V / 220V
POWER	1200 WATT
SIZE	WIDTH 470 MM X DEPTH 765 MM X HEIGHT 470 MM
WEIGHT	99 KG

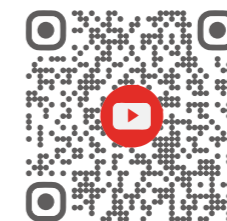

SCAN QR CODE FOR VIDEO OF THIS DOUGH PRESS



# CLAMSHELL DOUGH PRESS

- ✓ Uniform crusts
- ✓ Manual pressing
- ✓ Ideal for various dough types
- ✓ Easily adjustable dough thickness
- ✓ Even heating
- ✓ Temperature control

Easy operation manual type pizza dough press machine flattens the dough ball into uniform crusts in a little time. With this unit, you could easily press a variety of dough types for making the Mexican Tortilla, Pizza Crust, Pita Bread, Chapati, Parathas, and Lavash that kind food.



### FEATURES

- > Clamshell Design
- > Heated Platen
- > Thickness Adjustable
- > Durable
- > Up to 18 Inches Dia.
- > Timer and Temp Control



MODEL	ME-P18E-U	ME-P18E-UB	ME-P18E-N	ME-P18ES
PLATE SIZE	18 INCH	18 INCH	18 INCH	16 X 20 INCH
PLATE SHAPE	ROUND	ROUND	ROUND	RECTANGLE
HEATED METHOD	UPPER HEATING	UPPER AND BOTTOM HEATING	NO HEATING	UPPER AND BOTTOM HEATING
TEMPERATURE	MAX. 212°F (100°C)	MAX. 446°F (230°C)	N/A	MAX. 446°F (230°C)
VOLTAGE	110V / 220V	220V	N/A	220V
POWER	1200 WATT	3300 WATT	N/A	3600 WATT
SIZE	470X765X470 MM (CLOSE SIZE)	470X765X470 MM (CLOSE SIZE)	470X765X470 MM (CLOSE SIZE)	470X816X470 MM (CLOSE SIZE)
WEIGHT	49 KG	51 KG	47 KG	57 KG



SCAN QR CODE FOR VIDEO OF THIS CLAMSHELL DOUGH PRESS

# SWING AWAY DOUGH PRESS

The swing away type dough press is ideal for crafting pizza crusts, as it yields a texture akin to hand-stretched dough specifically for 18" crusts. Notably user-friendly, it ensures safety and is suitable even for unskilled labor. With a single press, it dramatically accelerates the production process while delivering impeccable dough quality.

- ✓ Swing Away Design
- ✓ Upper and Bottom Heating
- ✓ Thickness Adjustable
- ✓ Durable
- ✓ Up to 18 Inches Dia.
- ✓ Timer and Temp Control



MODEL	ME-SP18E-U Upper Heating	ME-SP18E-UB Upper and Bottom Heating
PLATE SIZE	18 INCH (457.2 MM)	18 INCH (457.2 MM)
TEMPERATURE	MAX. 212°F (100°C)	MAX. 446°F (230°C)
VOLTAGE	120V	240V
POWER	1650 WATT	3300 WATTS (1650 + 1650)
SIZE	610X476X412 MM	610X476X412 MM
WEIGHT	97 KG	99 KG
MAX. SWING ANGLE	90°C	90°C
ADJUSTABLE THICKNESS	1 - 30 MM	1 - 30 MM



SCAN QR CODE FOR VIDEO OF THIS SWING AWAY DOUGH PRESS

# ICE CREAM BLENDING MACHINE



- ✓ Automatic Blending
- ✓ Perfect for Ice Cream Shop
- ✓ Quick and Easy Processing
- ✓ High Return on Investment

The Frozen Yogurt Ice Cream Blending Machine is an automatic button blender that combines yogurt or ice cream with nuts, chilled fruits, and other ingredients, offering unlimited flavor combinations.

- > Best Ice Cream or Frozen Yogurt: -15°C to -18°C.
- > Best fruit temperature: -5°C to 0°C.
- > Best serving size is made up of:  
2 Scoops of Ice Cream or Frozen Yogurt  
1-2 Scoops of Fruit (or other ingredients)  
Best Ingredient Weight for Each scoop: 60 gram.

## RECOMMENDED INGREDIENTS TO BLEND



## FINAL ICE CREAM



MODEL	TF-1200
SIZE	320X550X700 MM (CLOSED) / 320X650X900 MM (OPEN)
WEIGHT	50 KG
POWER	750 WATTS
VOLTAGE	220V / 110 V
OPERATION TIME	10 SECONDS / SERVE
TEMPERATURE REQUIRED	-15°C TO -18°C (ICE CREAM) / -5°C TO 0°C (FRUIT)

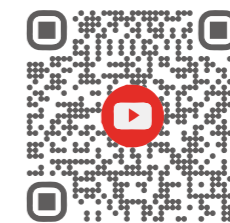

SCAN QR CODE FOR VIDEO OF THIS BLENDER



# EMPANADA TURNOVER MACHINE



- ✓ Fast and Efficient Production
- ✓ Easy and Simple Operation
- ✓ Perfect Seal Ensured
- ✓ Full Stainless Steel Body
- ✓ Various Die Casting Options

The DEM-10 Manual Pastries Meat Pie Empanadas Maker Turnover Machine is a automatic and versatile machine capable of producing 500 to 600 Empanadas or Samosas per hour with a single operation, without the need for prior experience or specialized knowledge.



### VARIOUS DIES

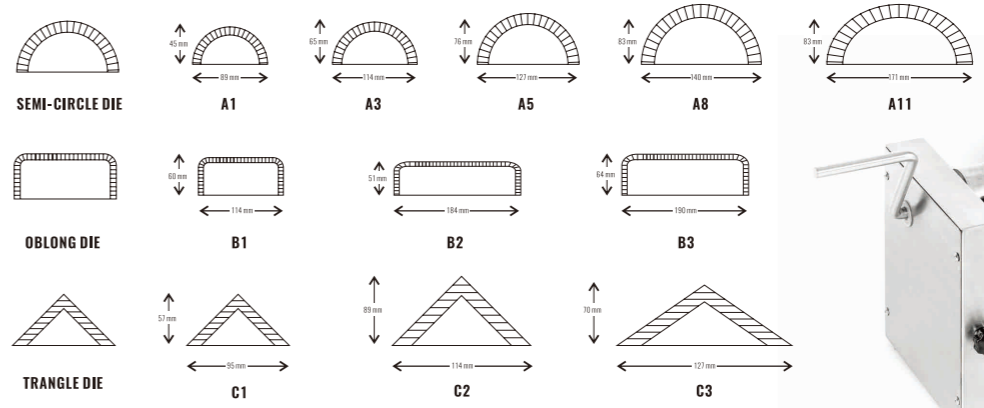

<b>MODEL</b>	DEM-10
<b>MACHINE SIZE</b>	520X250X270 MM
<b>NET WEIGHT</b>	9.5 KG
<b>PRODUCTION</b>	600 PCS / HOUR
<b>MATERIAL</b>	STAINLESS STEEL 304 / 1.5 MM THICKNESS



SCAN QR CODE FOR VIDEO OF THIS TURNOVER MACHINE

# BREAD SLICER

- ✓ Easy Blade Replacement
- ✓ Durable Blades
- ✓ Stable Performance
- ✓ Compact Design
- ✓ ETL Certified

Slice the bread into equally sized slices with several simple steps. The unit is designed with fixed slicing thickness, allow to cut a loaf of bread into the same thicknesses of slice quickly and precisely. Smaller space occupation, easy to replace the slicing blade, low noise, and stable performance.



## OPTIONAL FEATURES

**Bread Pusher** is optional to install, which provides enough distance from the workers' operation hands to the machine slicing blade, reducing the potential injury.

**Bread Bagger** is optional, easily wrap and pack the bread with the bagger on the top safety board.

**Protective Guard** is optional that to protect the operator's hands, to ensure a safe bread slicing operation.

**Breadcrumb Tray** is optional, installed under the machine, allow to easily collecting and cleaning the bread crumbs.

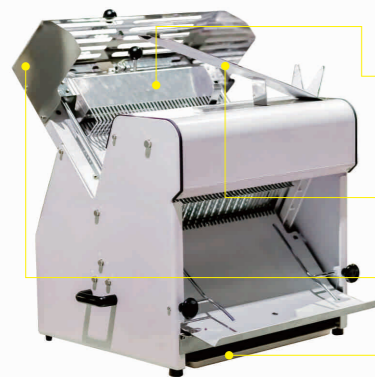

MODEL	TT-D7BE
SLICE THICKNESS	12 MM / 16 MM / 19 MM / 25 MM (NOT ADJUSTABLE)
MAX BREAD	475 MM X 150 MM (WIDTH X HEIGHT)
VOLTAGE	110V / 220V
POWER	200 WATT
SIZE	675X630X740 MM
WEIGHT	80 KG

# DOUGH SHEETER

- ✓ Reversible dough sheeter
- ✓ Easily roll dough to the desired thickness
- ✓ Consistent Dough Thickness
- ✓ ETL Certified

The reversible dough sheeter is ideal for bakeries and pizzerias to sheet and stretches the dough, finish the dough preparation job. Having the right tools makes a huge difference. The reversible dough sheeters machine makes it possible to achieve the consistent thickness of dough and allows to work quickly.



## HIGH EFFICIENCY DOUGH SHEETER

With this reversible dough sheeter, you can easily roll dough to the right thickness for the intended purpose. The dough sheeter could quickly roll out several pounds of dough per minute. No need to worry about running out of the prepared dough, it is easy to meet the high demands of



SCAN QR CODE FOR VIDEO OF THIS DOUGH SHEETER



MODEL	TT-D18A	TT-D18B	TT-D19A-1	TT-D19B-1
CONVEYOR BELT SIZE	430X1700 MM	500X2000 MM	500X2000 MM	630X2400 MM
WORKING WIDTH / HEIGHT	1770 MM / 620 MM	2080 MM / 620 MM	2550 MM / 1180 MM	2950 MM / 1180 MM
RESTING WIDTH / HEIGHT	750 MM / 710 MM	750 MM / 840 MM	660 MM / 1600 MM	780 MM / 1780 MM
ROLLER SIZE	DIA. 88X450 MM	DIA. 88X520 MM	DIA. 90X520 MM	DIA. 93X630 MM
VOLTAGE / POWER	110V / 220V / 560 WATT	110V / 220V / 560 WATT	110V / 220V / 560 WATT	110V / 220V / 750 WATT
SIZE	820X1770X620 MM	880X2080X620 MM	880X2550X1180 MM	1100X2950X1180 MM
WEIGHT	117 KG	125 KG	190 KG	225 KG



# BLAST CHILLER FREEZER



- ✓ Italian Dixell Thermostat
- ✓ Stainless Steel 304 Body
- ✓ EBM German Blower
- ✓ Ventilated
- ✓ Embraco / Tecumseh Compressor
- ✓ 75 MM Thickness Insulation

Blast chiller freezers are high-end appliances that swiftly cool freshly prepared food, preserving its quality and freshness when stored. The rapid temperature reduction is vital for maintaining dish quality and preventing bacterial growth. The undeniable advantages of blast chillers in commercial kitchens make them essential for professional chefs and catering services.

### FAST REFRIGERATION SPEED

This blast freezer can freeze products within 30 minutes with a temperature range of +90°C to -30°C, significantly reducing the risk of bacteria growth due to its efficient cooling speed.



SCAN QR CODE FOR VIDEO OF THIS BLAST CHILLER



MODEL	GC-BC3	GC-BC5	GC-BC10	GC-BC15
TRAY QTY	3 TRAYS	5 TRAYS	10 TRAYS	15 TRAYS
CHAMBER CAPACITY	40 LITER	160 LITER	310 LITER	345 LITER
CHAMBER SIZE	340X365X320 MM	650X400X425 MM	650X755X425 MM	650X1085X425 MM
SIZE	725X665X515 MM	790X730X913 MM	790X730X1398 MM	790X730X1807 MM
WEIGHT	58 KG	93 KG	128 KG	185 KG
POWER	500 WATTS	870 WATTS	1100 WATTS	1950 WATTS
COMPRESSOR	EMBRACO / SECOP	EMBRACO / SECOP	EMBRACO / SECOP	TECUMSEH



SERVE SINCE 2000

**TWOTHOUSAND**

INTELLIGENT COMMERCIAL KITCHEN EQUIPMENT MANUFACTURER